

**PARTS  
CATALOGUE  
CATALOGUE  
DE PIÈCES DÉTACHÉES**

**F40C'03 (60K2)**

**F60A'03 (69W2)**

2B69W-300F1

**YAMAHA**  
**GENUINE**  
Parts & Accessories

2009/3/31

NEWS NO.	DATE	COMMENT
PE0-OM-070046	Oct.,30,2007	COR:FIG.19 PTT(69W-43800-00-4D) P/No. CORRECTION
PE0-OM-090015	March,2,2009	MOD:FIG.18,19 PTT(69W-43800-00-8D) P/No. REVISION

# FOREWORD

This Parts Catalogue is related to the parts for the model(s) in the below frame. When you are ordering replacement parts, please refer to this Parts Catalogue and quote both part numbers and part names correctly.

F40C'03(60K2), F60A'03(69W2)

1. Modifications or additions which have been made after issue of the Parts Catalogue will be announced in the Yamaha Parts News.  
It is advisable that you make necessary corrections to the Parts Catalogue according to the Yamaha Parts News.

2. Abbreviations

The Following abbreviations are used in this Parts Catalogue.

“UR” Use specified parts number.

“UN” Use as many as needed.

“AP” Alternate Parts

“LM” Local Made  
(Parts need to be ordered locally)

“O/S” Over Size

3. Parts, which are to be supplied in an assembly, are listed with a dot(.) in front of the part name as shown below.

EXAMPLE

CARBURETOR ASSY

.JET, PILOT

.NOZZLE, MAIN

4. Number of component for assembly

The numeral appearing to the right of each component part indicates the quantity of parts for each assembly unit.

EXAMPLE

PART NO.	DESCRIPTION	u	u	u	u	REMARKS
6E0-85500-70	C.D.I. MAGNETO ASSY	1				
6E0-85550-70	.ROTOR ASSY	1				
6E0-15723-00-94..	PULLY, STARTER	1				

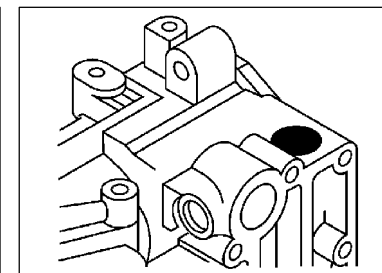
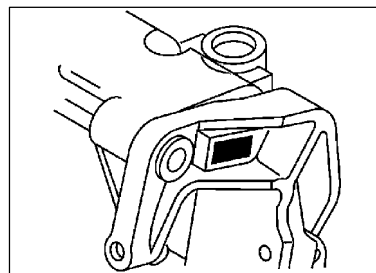
5. Quantity Column Information

NAME for Q'TY COLUMN	APPLICABLE MODEL
F60A	F60AET
F40C	F40CET

6. Applicable Starting Serial No. and Color Code

1) Engine Starting Sserial No.

F40CET L 60K : 1000001	F60AET L 69W : 1000001
------------------------	------------------------



2) Color Code

Color Code	Color Name	Abbreviation
004D	DARK BLUIISH GRAY METALLIC 2	DBNM2

7. Note that the illustrations for reference in finding parts numbers, not to be used for assembling. When assembling, please use the applicable service manual.

8. The asterisk (\*) before a reference number indicates modification items after the first edition.

# CONTENTS

## SHEET 1/2

TOP COWLING .....	A4
CYLINDER. CRANKCASE 1 .....	A5
CRANKSHAFT. PISTON .....	A7
CYLINDER. CRANKCASE 2 .....	B1
VALVE .....	B3
INTAKE .....	B4
CARBURETOR .....	B6
OIL PUMP .....	C1
FUEL .....	C2
GENERATOR .....	C4
ELECTRICAL 1 .....	C5
ELECTRICAL 2 .....	C6
STARTING MOTOR .....	D1
BOTTOM COWLING .....	D2
CONTROL .....	D4
BRACKET 1 .....	D6
BRACKET 2 .....	E1
POWER TRIM & TILT ASSY 1 .....	E3
POWER TRIM & TILT ASSY 2 .....	E6
UPPER CASING .....	E7
OIL PAN .....	F2
LOWER CASING. DRIVE 1 .....	F3
LOWER CASING. DRIVE 2 .....	F6

## INDEX

NUMERICAL INDEX .....	G1
-----------------------	----

## SHEET 2/2

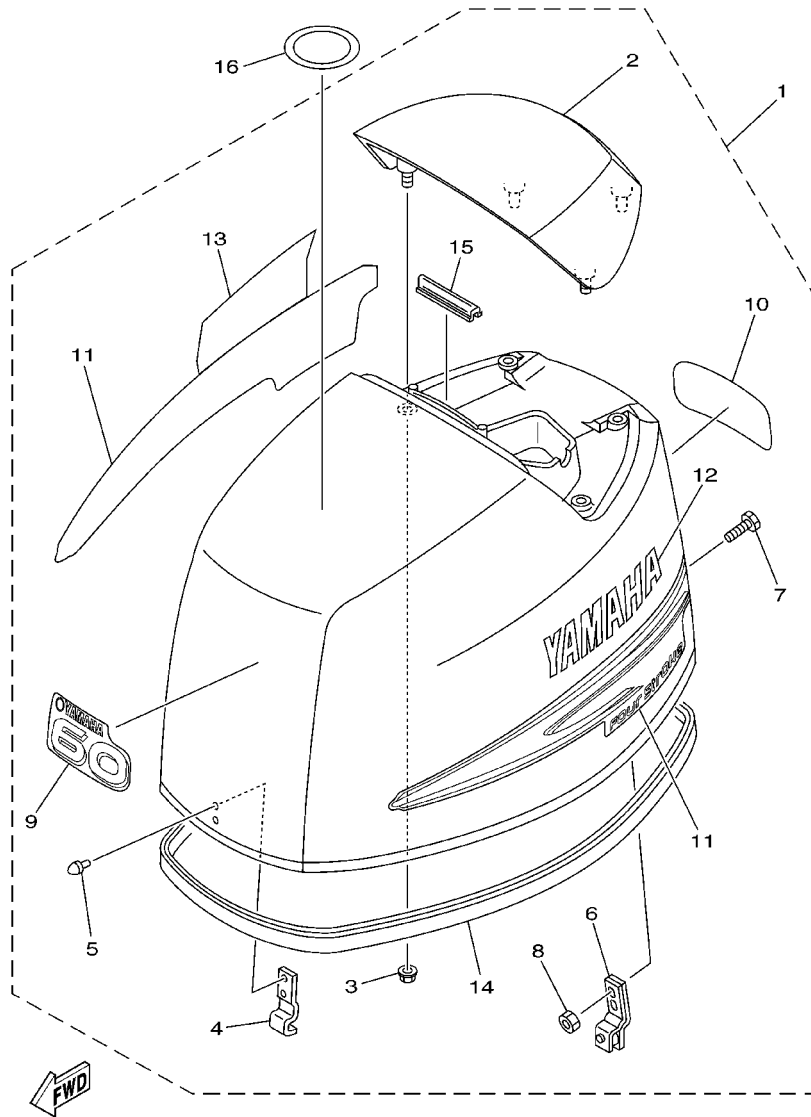
FUEL TANK .....	A4*
STEERING GUIDE .....	A5*
REMOTE CONTROL BOX .....	A6*
REMOTE CONTROL ASSY .....	A7*
METER .....	B3*
REPAIR KIT 1 .....	B4*
REPAIR KIT 2 .....	B5*
REPAIR KIT 3 .....	B6*

## INDEX

NUMERICAL INDEX .....	G1*
-----------------------	-----

FIG. 1 TOP COWLING

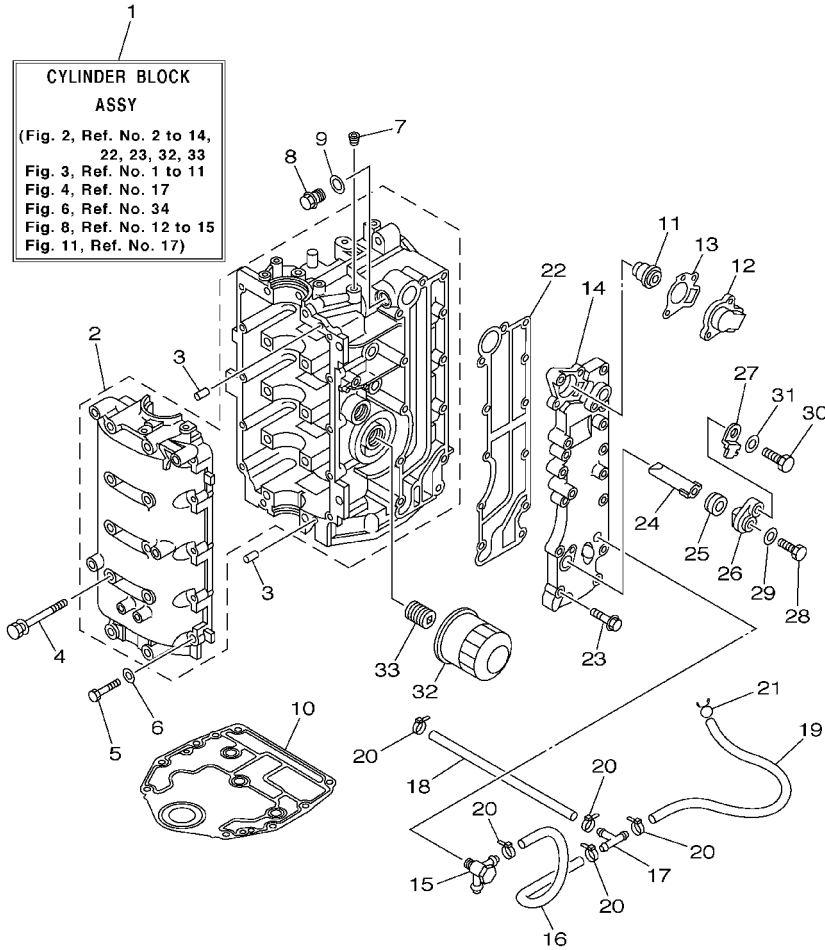
CAPOT SUPERIEUR



69W1010-2010

REF. NO.	PART NO. NO. PIECES	DESCRIPTION DESCRIPTION	F60A	F40C	REMARKS REMARQUES
1	69W-42610-00-4D	TOP COWLING ASSY CAPOT (ENS.)	1		
	60K-42610-00-4D	TOP COWLING ASSY CAPOT (ENS.)		1	
2	67C-42613-00-4D	.MOLDING, AIR DUCT .MANCHON A AIR	1	1	
3	90179-06M24	.NUT .ECROU	4	4	
4	62Y-42651-00	.HOOK .CROCHET	1	1	
5	90266-06M02	.RIVET .RIVET	2	2	
6	67C-42652-00	.HOOK .CROCHET	1	1	
7	90109-06047	.BOLT .BOULON	2	2	
8	95680-06100	.NUT, U .ECROU, U	2	2	
9	69W-42677-00	.GRAPHIC, FRONT .ADHESIF, AVANT	1		
	62Y-42677-50	.GRAPHIC, FRONT .ADHESIF, AVANT		1	
10	69W-42678-00	.GRAPHIC, REAR .ADHESIF, ARRIERE	1		
	62Y-42678-50	.GRAPHIC, REAR .ADHESIF, ARRIERE		1	
11	69W-W0070-00	.GRAPHIC SET .JEU DIEMBLEMES	1	1	
12	69W-42681-00	.MARK, COWLING .ADHESIF, CAPOT	1	1	
13	69W-42682-00	.MARK, COWLING .ADHESIF, CAPOT	1	1	
14	69W-42615-00	.SEAL .JOINT	1	1	
15	61N-42628-00	.SEAL .JOINT	1	1	
16	67F-13434-02	LABEL, CAUTION ETIQUETTE, ATTENTION	1	1	

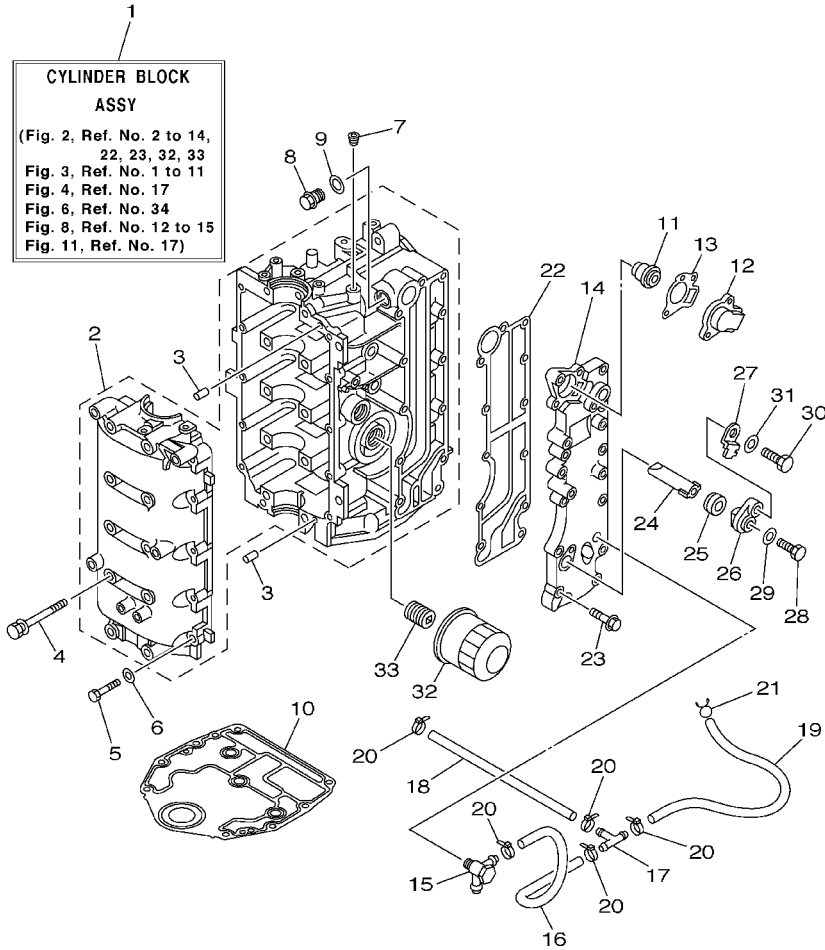
FIG. 2 CYLINDER. CRANKCASE 1 CYLINDRE. CARTER 1



**CYLINDER BLOCK ASSY**  
 (Fig. 2, Ref. No. 2 to 14, 22, 23, 32, 33  
 Fig. 3, Ref. No. 1 to 11  
 Fig. 4, Ref. No. 17  
 Fig. 6, Ref. No. 34  
 Fig. 8, Ref. No. 12 to 15  
 Fig. 11, Ref. No. 17)

REF. NO.	PART NO. NO. PIECES	DESCRIPTION DESCRIPTION	F60A	F40C	REMARKS REMARQUES
1	69W-W009B-00-1S	CYLINDER BLOCK ASSY CYLINDRE GROUPE (ENS.)	1	1	
2	69W-15100-00-1S	CRANKCASE ASSY CARTER DE MOTEUR COMPLET	1	1	
3	93606-12019	PIN, DOWEL GOUPILLE	4	4	
4	90119-08M01	BOLT, WITH WASHER BOULON, AVEC RONDELLE	10	10	
5	97013-06035	BOLT BOULON	10	10	
6	92903-06600	WASHER, PLATE RONDELLE, PLATE	10	10	
7	90344-51003	PLUG, TAPER SCREW PLOT, FILETE CONIQUE	1	1	
8	90340-14M06	PLUG, STRAIGHT SCREW PLOT, FILETE DROIT	1	1	
9	90430-14115	GASKET JOINT	1	1	
10	67C-11351-00	GASKET, CYLINDER JOINT, D'EMBASE	1	1	
11	6G8-12411-02	THERMOSTAT THERMOSTAT	1	1	
12	6H3-12413-00-1S	COVER, THERMOSTAT COUVERCLE, THERMOSTAT	1	1	
13	62Y-12414-00	GASKET, COVER JOINT, COUVERCLE	1	1	
14	62Y-41113-20-1S	OUTER COVER, EXHAUST COUVERCLE, ECHAPPEMENT	1	1	
15	62Y-11372-01	NIPPLE, HOSE RACCORD, TUYAU	1	1	FOR FLUSHING KIT
16	90445-09068	HOSE (L110) DURITE (L110)	1	1	
17	688-24378-00	PIPE, JOINT 4 DURITE RACCORDEMENT 4	1	1	
18	90445-09095	HOSE (L215) DURITE (L215)	1	1	
19	90445-09105	HOSE (L300) DURITE (L300)	1	1	
20	90465-11M10	CLAMP BRIDE	5	5	
21	90467-08M18	CLIP JONC	1	1	
22	62Y-41114-00	GASKET, EXHAUST OUTER COVER JOINT, COUVERCLE D'ECHAPPEMENT	1	1	
23	90119-06MA5	BOLT, WITH WASHER BOULON, AVEC RONDELLE	12	12	
24	62Y-11325-00	ANODE ANODE	1	1	
25	66M-11328-00	GROMMET, ANODE PASSE-FIL	1	1	
26	66M-11327-00-94	COVER, ANODE COUVERCLE	1	1	
27	66M-12535-00	PLATE PLAQUE	1	1	

  
 69W2300-3020



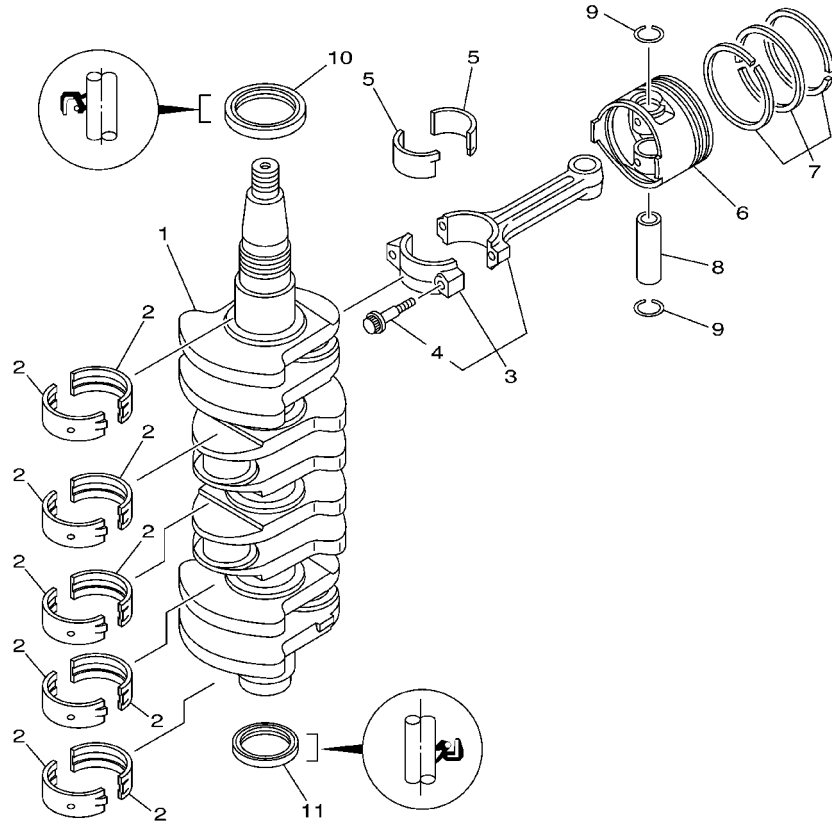
**FIG. 2 CYLINDER. CRANKCASE 1 CYLINDRE. CARTER 1**

REF. NO.	PART NO. NO. PIECES	DESCRIPTION DESCRIPTION	F60A	F40C	REMARKS REMARQUES
28	97095-05012	BOLT BOULON	1	1	
29	92995-05600	WASHER RONDELLE	1	1	
30	97095-06020	BOLT BOULON	1	1	
31	92995-06600	WASHER RONDELLE	1	1	
32	5GH-13440-00	ELEMENT ASSY, OIL CLEANER ELEMENT, FILTRE A HUILE	1	1	
33	90401-20M00	BOLT, UNION BOULON, RACCORD	1	1	

  
69W2300-3020

FIG. 3 CRANKSHAFT. PISTON

VILEBREQUIN. PISTON

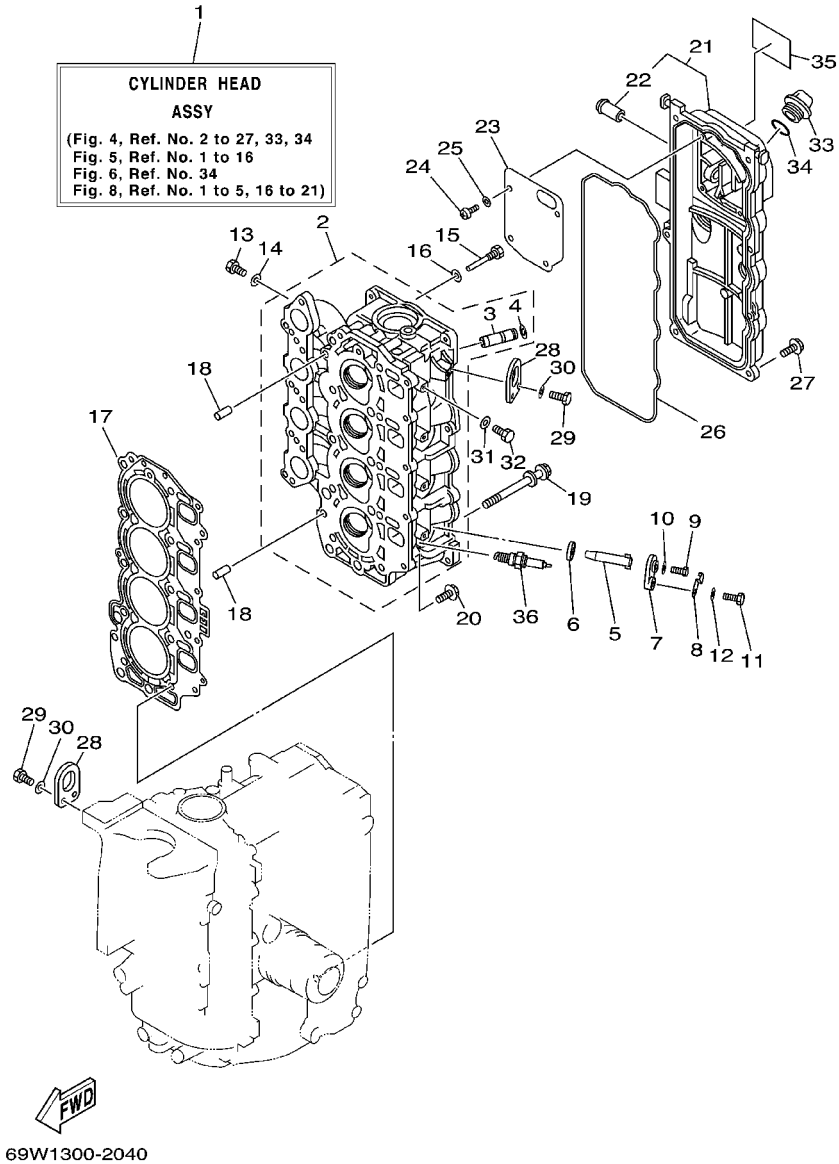


REF. NO.	PART NO. NO. PIECES	DESCRIPTION DESCRIPTION	F60A	F40C	REMARKS REMARQUES
1	69W-11411-00	CRANKSHAFT VILEBREQUIN COMPLET	1	1	
2	62Y-11416-30	PLANE BEARING, CRANKSHAFT 1 COUSSINET DE VILEBREQUIN 1	10	10	UR YELLOW
	62Y-11416-40	PLANE BEARING, CRANKSHAFT 1 COUSSINET DE VILEBREQUIN 1	10	10	UR RED
	62Y-11416-50	PLANE BEARING, CRANKSHAFT 1 COUSSINET DE VILEBREQUIN 1	10	10	UR PINK
	62Y-11416-60	PLANE BEARING, CRANKSHAFT 1 COUSSINET DE VILEBREQUIN 1	10	10	UR GREEN
3	62Y-11650-10	CONNECTING ROD ASSY BIELLE COMPLETE	4	4	
4	62Y-11654-00	.BOLT, CONNECTING ROD .BOULON, BIELLE	2	2	
5	62Y-11656-30	PLANE BEARING, CONNECTING ROD ROULEMENT DE BIELLE	8	8	UR YELLOW
	62Y-11656-40	PLANE BEARING, CONNECTING ROD ROULEMENT DE BIELLE	8	8	UR RED
	62Y-11656-50	PLANE BEARING, CONNECTING ROD ROULEMENT DE BIELLE	8	8	UR PINK
	62Y-11656-60	PLANE BEARING, CONNECTING ROD ROULEMENT DE BIELLE	8	8	UR GREEN
6	69W-11631-00-97	PISTON (STD) PISTON (STD)	4	4	
	69W-11635-00	PISTON (0.25MM O/S) PISTON (0.25MM O/S)	4	4	AP
	69W-11636-00	PISTON (0.50MM O/S) PISTON (0.50MM O/S)	4	4	AP
7	67C-11603-00	PISTON RING SET (STD) JEU DE SEGMENTS (STD)	4	4	
	67C-11604-00	PISTON RING SET (0.25MM O/S) JUE DE SEGMENTS (0.25MM O/S)	4	4	AP
	67C-11605-00	PISTON RING SET (0.50MM O/S) JEU DE SEGMENTS (0.50MM O/S)	4	4	AP
8	62Y-11633-00	PIN, PISTON AXE, PISTON	4	4	
9	93450-17129	CIRCLIP CIRCLIP	8	8	
10	93102-43M42	OIL SEAL JOINT SPY	1	1	
11	93101-35002	OIL SEAL JOINT SPY	1	1	



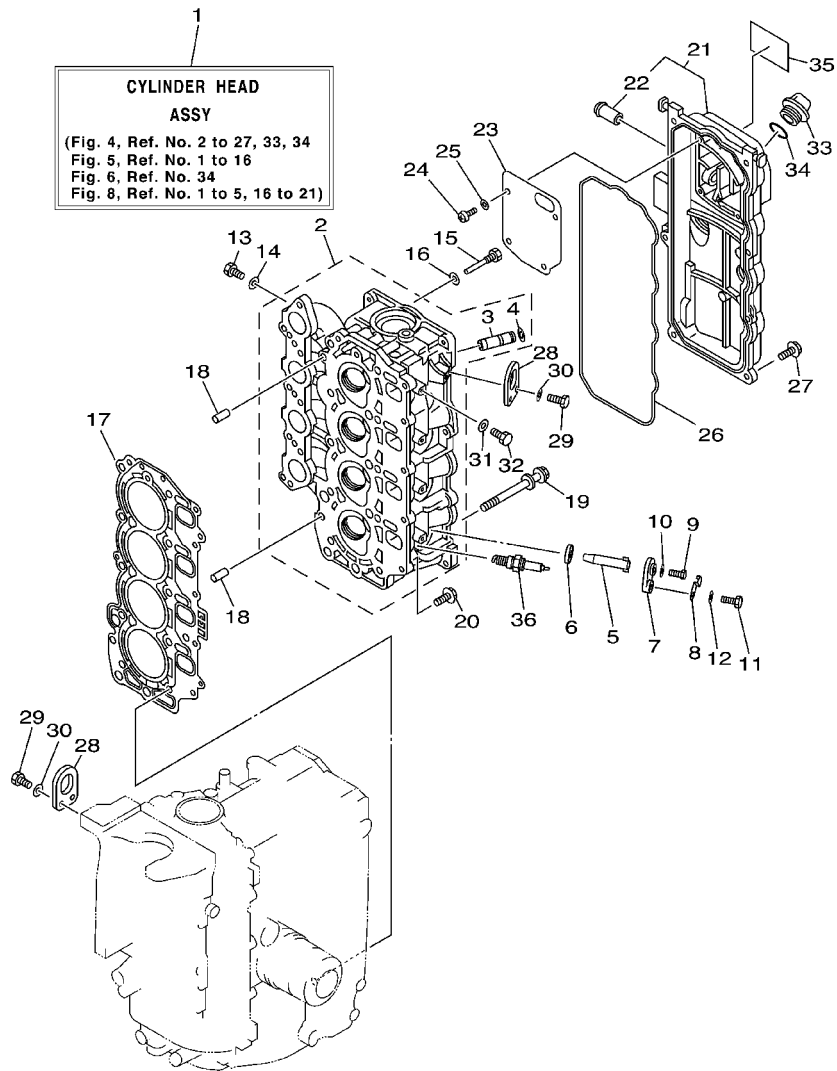
69W1010-2030

FIG. 4 CYLINDER. CRANKCASE 2 CYLINDRE. CARTER 2



REF. NO.	PART NO. NO. PIECES	DESCRIPTION DESCRIPTION	F60A	F40C	REMARKS REMARQUES
1	69W-W009A-00-1S	CYLINDER HEAD ASSY CULASSE (ENS.)	1	1	
2	69W-11111-00-1S	HEAD, CYLINDER 1 CULASSE	1	1	
3	62Y-11133-30	.GUIDE, INTAKE VALVE .GUIDE, SOUP D'ADM	8	8	
4	93450-09M01	.CIRCLIP .CIRCLIP	8	8	
5	62Y-11325-00	ANODE ANODE	4	4	
6	66M-11328-00	GROMMET, ANODE PASSE-FIL	4	4	
7	66M-11327-00-94	COVER, ANODE COUVERCLE	4	4	
8	66M-12535-00	PLATE PLAQUE	4	4	
9	97095-05012	BOLT BOULON	4	4	
10	92995-05600	WASHER RONDELLE	4	4	
11	97095-06020	BOLT BOULON	4	4	
12	92995-06600	WASHER RONDELLE	4	4	
13	97095-06010	BOLT BOULON	4	4	
14	90430-06014	GASKET JOINT	4	4	
15	90109-06M65	BOLT BOULON	1	1	
16	90430-06014	GASKET JOINT	1	1	
17	69W-11181-00	GASKET, CYLINDER HEAD 1 JOINT, DE CULASSE 1	1	1	
18	99530-08012	PIN, DOWEL GOUJON, D'ASSEMBLAGE	2	2	
19	90119-09M00	BOLT, WITH WASHER BOULON, AVEC RONDELLE	10	10	
20	90119-06MA3	BOLT, WITH WASHER BOULON, AVEC RONDELLE	5	5	
21	62Y-11191-01-1S	COVER, CYLINDER HEAD 1 COUVERCLE, CULASSE 1	1	1	
22	62Y-14485-00	.PIPE, JOINT .DURITE	1	1	
23	62Y-11168-00	COVER, BREATHER COUVERCLE, RENIFLARD	1	1	
24	98507-04010	SCREW VIS	4	4	
25	92907-04600	WASHER RONDELLE	4	4	
26	62Y-11356-00	SEAL, CYLINDER 2 JOINT, SPY CYLINDRE	1	1	
27	97595-06520	BOLT, WITH WASHER VIS HEXAGONAL AVC RONDELLE	7	7	





**1**  
**CYLINDER HEAD**  
**ASSY**  
 (Fig. 4, Ref. No. 2 to 27, 33, 34  
 Fig. 5, Ref. No. 1 to 16  
 Fig. 6, Ref. No. 34  
 Fig. 8, Ref. No. 1 to 5, 16 to 21)

69W1300-2040



**FIG. 4 CYLINDER. CRANKCASE 2      CYLINDRE. CARTER 2**

REF. NO.	PART NO. NO. PIECES	DESCRIPTION DESCRIPTION	F60A	F40C	REMARKS REMARQUES
28	62Y-11119-00	HANGER, ENGINE ANNEAU, LEVAGE	2	2	
29	97095-06020	BOLT BOULON	4	4	
30	92995-06600	WASHER RONDELLE	4	4	
31	90430-08143	GASKET JOINT	4	4	
32	97095-08014	BOLT BOULON	4	4	
33	6G8-15363-00	PLUG, OIL PLOT, HUILE	1	1	
34	93210-24M79	O-RING JOINT TORIQUE	1	1	
35	62Y-12138-60	MARK, CAUTION MAKER	1	1	
36	94701-00406	PLUG, SPARK (NGK DPR5EA-9) BOUGIE D'ALLUMAGE (NGK DPR5EA-9)	4	4	
-----					
-----					
-----					
-----					
-----					
-----					
-----					
-----					
-----					
-----					

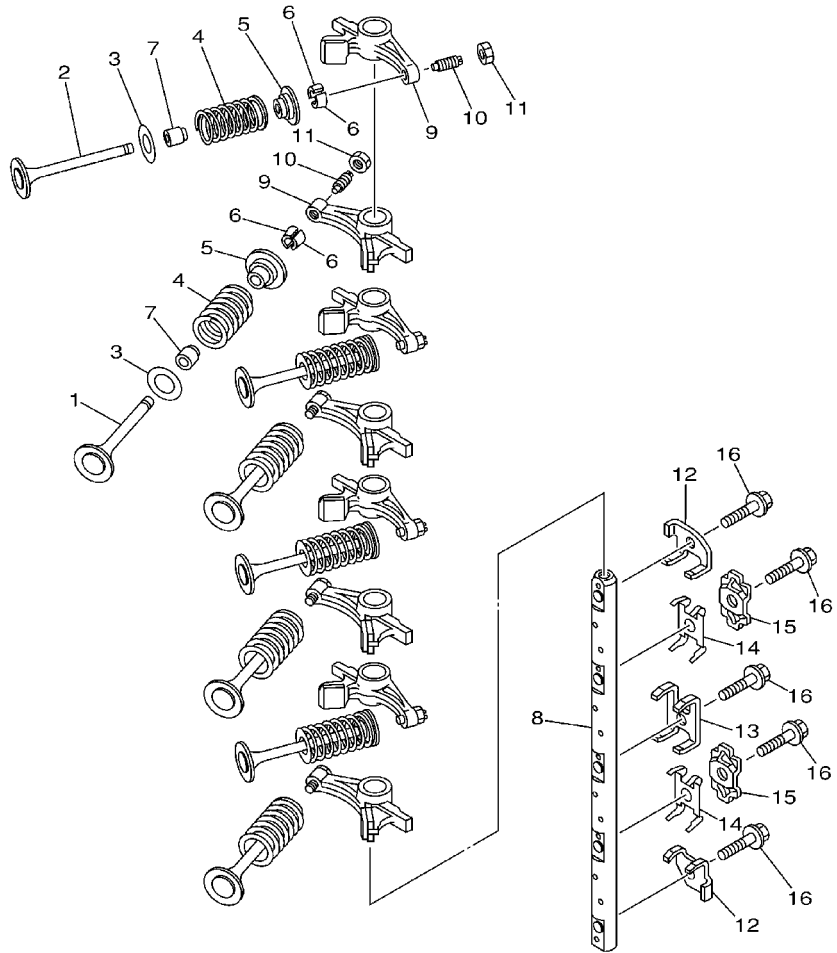


FIG. 5 VALVE

SOUPAPE

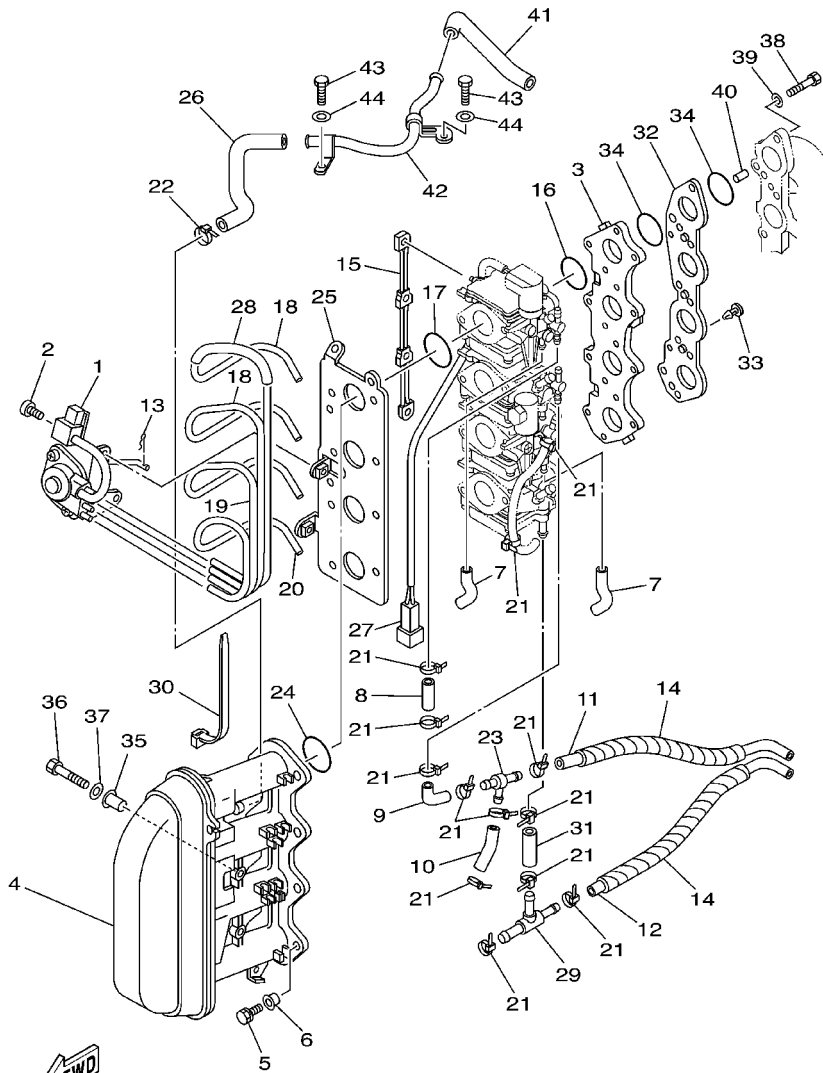
REF. NO.	PART NO. NO. PIECES	DESCRIPTION DESCRIPTION	F60A	F40C	REMARKS REMARQUES
1	69W-12111-00	VALVE, INTAKE SOUPAPE, ADMISSION	4	4	
2	69W-12121-00	VALVE, EXHAUST SOUPAPE, ECHAPPEMENT	4	4	
3	62Y-12116-00	SEAT, VALVE SPRING SIEGE, RESSORT DE SOUPAPE	8	8	
4	51Y-12114-00	SPRING, VALVE OUTER RESSORT DE SOUPAPE, EXTERNE	8	8	
5	30X-12117-00	RETAINER, VALVE SPRING BUTEE DE RESSORT DE SOUPAPE	8	8	
6	30X-12118-00	COTTER, VALVE FRAISE, SOUPAPE	16	16	
7	51Y-12119-00	SEAL, VALVE STEM JOINT, QUEUE DE SOUPAPE	8	8	
8	62Y-12146-00	SHAFT, ROCKER AXE, CULBUTEUR	1	1	
9	62Y-12151-00	ARM, VALVE ROCKER CULBUTEUR	8	8	
10	64J-12159-00	SCREW, VALVE ADJUSTING VIS, REGLAGE DE SOUPAPE	8	8	
11	62Y-12158-00	NUT, LOCK CONTRE-ECROU	8	8	
12	62Y-12238-00	PLATE, BOLT STOPPER PLAQUE, BUTEE DE BOULON	2	2	
13	62Y-12279-00	PLATE PLAQUE	1	1	
14	62Y-12216-00	SPRING RESSORT	2	2	
15	62Y-12231-00	GUIDE, STOPPER 1 GUIDE, BUTEE 1	2	2	
16	90109-08M63	BOLT BOULON	5	5	



62Y1010-2050

FIG. 6 INTAKE

ADMISSION

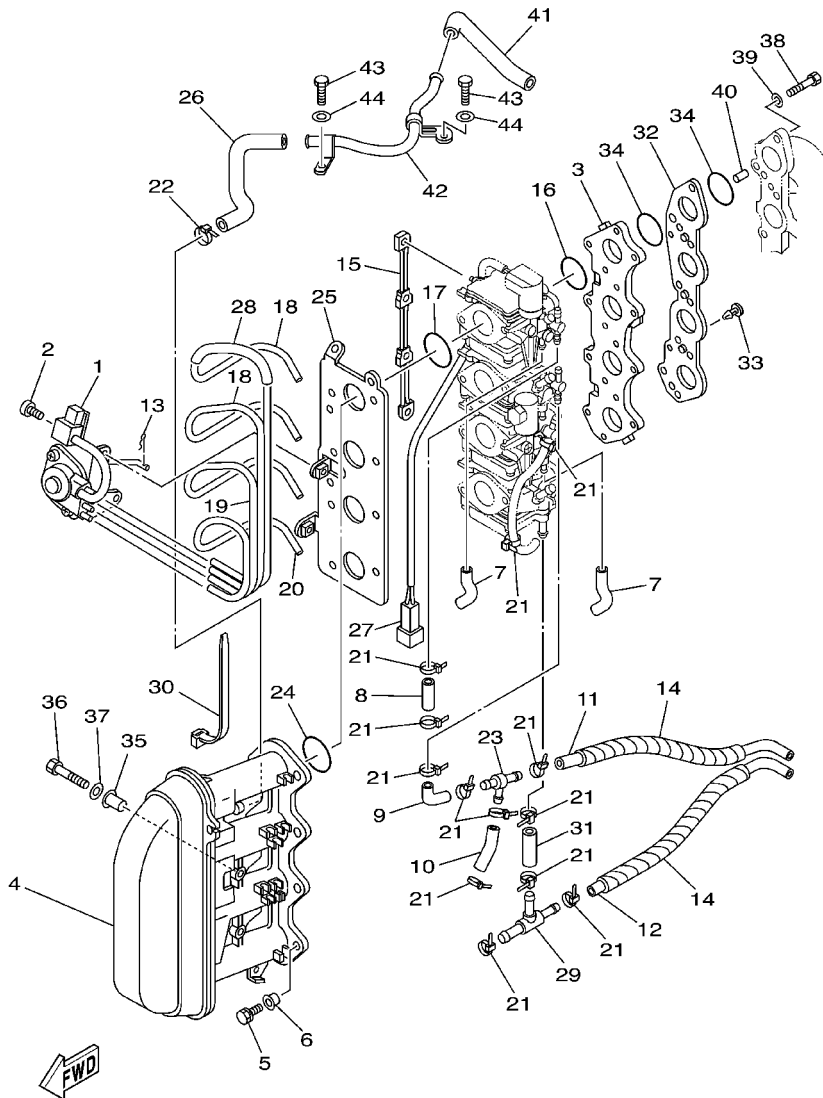


69W1100-2060

REF. NO.	PART NO. NO. PIECES	DESCRIPTION DESCRIPTION	F60A	F40C	REMARKS REMARQUES
1	69W-14369-00	DIAPHRAGM ASSY 2 DIAPHRAGME 2	1	1	
2	650-14327-01	SCREW VIS	3	3	
3	69W-13586-00	JOINT, CARBURETOR 1 RACCORD, CARBURATEUR 1	1	1	
4	69W-14440-00	SILENCER ASSY, INTAKE SIENCIEUX D'ADMISSION	1	1	
5	97595-06590	BOLT, WITH WASHER VIS HEXAGONAL AVC RONDELLE	8	8	
6	90387-06M70	COLLAR COLLERETTE	8	8	
7	62Y-24312-00	PIPE 2 DURITE 2	2	2	
8	62Y-24313-30	PIPE 3 DURITE 3	1	1	
9	62Y-24313-40	PIPE 3 DURITE 3	1	1	
10	62Y-24313-50	PIPE 3 DURITE 3	1	1	
11	62Y-24313-61	PIPE 3 DURITE 3	1	1	
12	62Y-24313-70	PIPE 3 DURITE 3	1	1	
13	69W-23153-00	RING, SNAP JONC, ARRET	1	1	
14	69W-24313-80	PIPE 3 DURITE 3	2	2	
15	64J-14585-00	ROD, CHOKE TRINGLE, STARTER	1	1	
16	69W-14561-00	O-RING JOINT TORIQUE	4	4	
17	93210-35M86	O-RING JOINT TORIQUE	4	4	
18	64J-14349-11	PIPE DURITE	2	2	
19	69W-14349-00	PIPE DURITE	1	1	
20	69W-14349-10	PIPE DURITE	1	1	
21	90465-11M10	CLAMP BRIDE	13	13	
22	90465-13M36	CLAMP BRIDE	1	1	
23	62Y-24378-00	PIPE, JOINT 4 DURITE RACCORDEMENT 4	1	1	
24	93210-38MH3	O-RING JOINT TORIQUE	4	4	
25	62Y-14291-30	BRACKET 1 SUPPORT 1	1	1	
26	62Y-1532B-00	PIPE, BREATHER DURITE DE RENIFLARD	1	1	
27	69W-82509-00	WIRE, SUB LEAD FIL, SECONDAIRE	1	1	

FIG. 6 INTAKE

ADMISSION

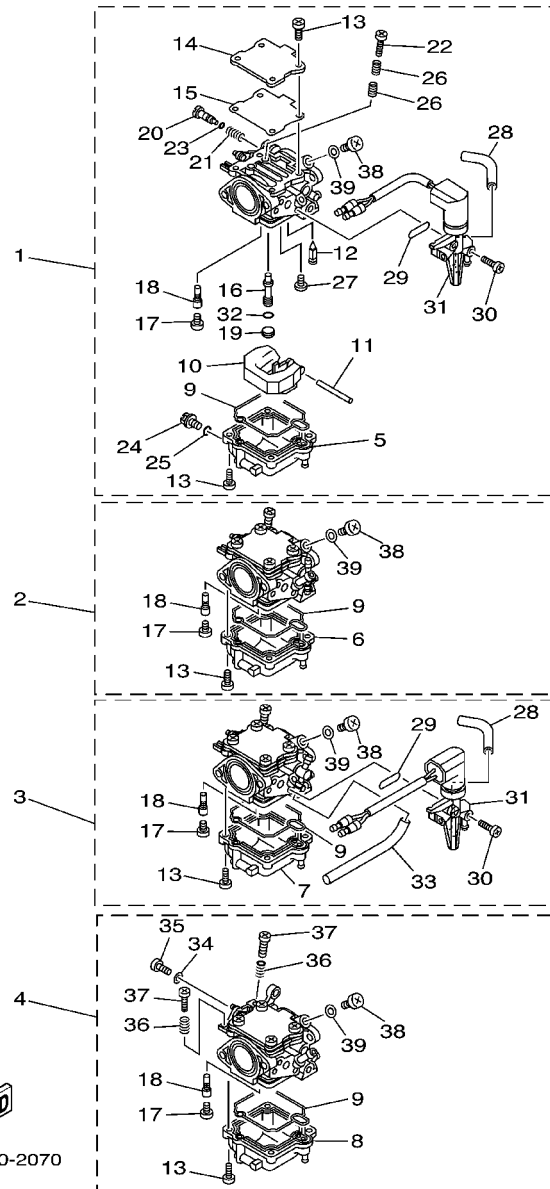


69W1100-2060

REF. NO.	PART NO. NO. PIECES	DESCRIPTION DESCRIPTION	F60A	F40C	REMARKS REMARQUES
28	64J-14349-40	PIPE DURITE	1	1	
29	62Y-24378-00	PIPE, JOINT 4 DURITE RACCORDEMENT 4	1	1	
30	62Y-82544-00	CLAMP COLLIER	1	1	
31	62Y-24314-00	PIPE 4 DURITE 4	1	1	
32	69W-14271-00	INSULATOR ISOLATEUR	1	1	
33	90338-04M17	PLUG PLOT	2	2	
34	93210-35M86	O-RING JOINT TORIQUE	8	8	
35	90387-06M15	COLLAR COLLERETTE	2	2	
36	97095-06030	BOLT BOULON	2	2	
37	92995-06600	WASHER RONDELLE	2	2	
38	97095-06025	BOLT BOULON	8	8	
39	92995-06600	WASHER RONDELLE	8	8	
40	93608-16M16	PIN, DOWEL AXE	2	2	
41	62Y-1531A-00	HOSE, BREATHER 1 DURITE DE RENIFLARD 1	1	1	
42	62Y-15373-10	PIPE, BREATHER DURITE DE RENIFLARD	1	1	
43	97095-06016	BOLT BOULON	2	2	
44	92995-06600	WASHER RONDELLE	2	2	

FIG. 7 CARBURETOR

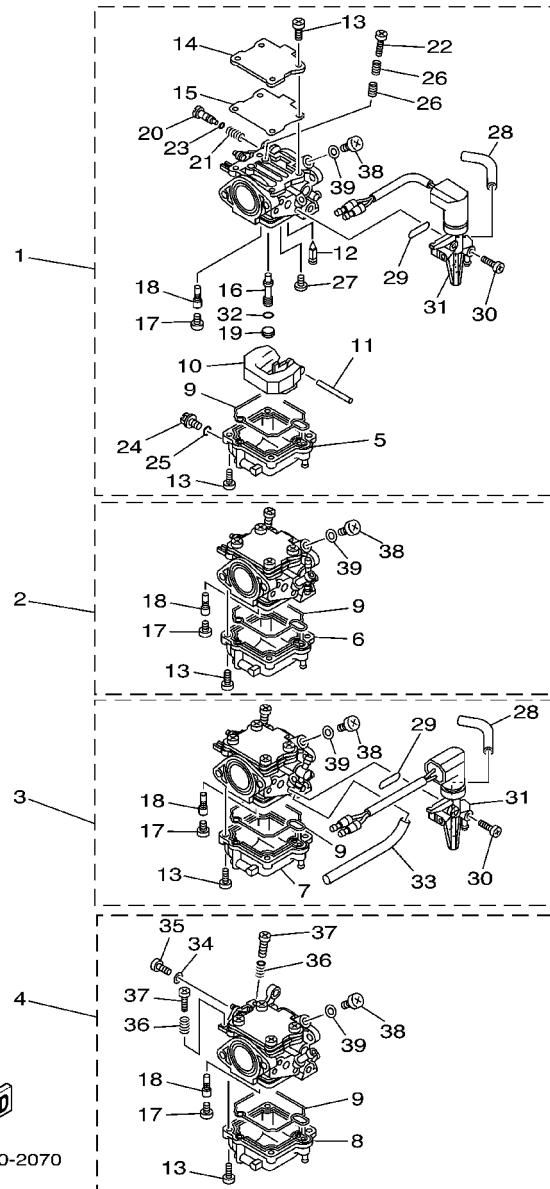
CARBURATEUR



REF. NO.	PART NO. NO. PIECES	DESCRIPTION DESCRIPTION	F60A	F40C	REMARKS REMARQUES
1	69W-14901-01	CARBURETOR ASSY 1 CARBURATEUR 1 COMPLET	1	1	
2	69W-14902-01	CARBURETOR ASSY 2 CARBURATEUR 2 COMPLET	1	1	
3	69W-14903-01	CARBURETOR ASSY 3 CARBURATEUR 3 COMPLET	1	1	
4	69W-14904-01	CARBURETOR ASSY 4 CARBURATEUR 4 COMPLET	1		
	60K-14904-01	CARBURETOR ASSY 4 CARBURATEUR 4 COMPLET		1	
5	69W-14381-00	.BODY, FLOAT CHAMBER .CORPS, CUVE DE FLOTTEUR	1	1	#1
6	69W-14381-10	.BODY, FLOAT CHAMBER .CORPS, CUVE DE FLOTTEUR	1	1	#2
7	69W-14381-20	.BODY, FLOAT CHAMBER .CORPS, CUVE DE FLOTTEUR	1	1	#3
8	69W-14381-30	.BODY, FLOAT CHAMBER .CORPS, CUVE DE FLOTTEUR	1	1	#4
9	69W-14384-00	.GASKET, FLOAT CHAMBER .JOINT, CUVE DE FLOTTEUR	4	4	
10	6L2-14385-00	.FLOAT .FLOTTEUR	4	4	
11	6E5-14386-01	.PIN, FLOAT .AXE, FLOTTEUR	4	4	
12	62Y-14392-00	.VALVE, NEEDLE .POINTEAU	4	4	
13	62Y-14321-00	.SCREW, THROTTLE .VIS, ACCELERATEUR	32	32	
14	62Y-14157-30	.COVER, MIXING .COUVERCLE DE CHAMBRE	4	4	
15	69W-14399-00	.VALVE, BIMETAL .CLAPET, BILAME	4	4	
16	69W-14341-00	.NOZZLE, MAIN .PUITS D'AIGUILLE	4	4	
17	69W-14343-62	.JET, MAIN (#124) .GICLEUR, PRINCIPAL (#124)	4	4	
18	64J-14342-20	.JET, PILOT (#39) .GICLEUR, RALENTI (#39)	4	4	
19	66M-14355-00	.PLUG .PLOT	4	4	
20	69W-14323-00	.SCREW, AIR ADJUSTING .VIS DE DOSEUR D'AIR	4	4	
21	62Y-14334-00	.SPRING, AIR ADJUSTING .RESSORT, VIS DE DOSEUR D'AIR	4	4	
22	62Y-14321-10	.SCREW, THROTTLE .VIS, ACCELERATEUR	4	4	
23	2T4-14397-00	.O-RING .JOINT TORIQUE	4	4	
24	62Y-14383-30	.SCREW, DRAIN .BOUCHON, PURGE	4	4	
25	652-14397-00	.O-RING .JOINT TORIQUE	4	4	
26	62Y-14212-00	.SPRING, PILOT ADJUSTING .RESSORT, VIS DE RALENTI	8	8	

FIG. 7 CARBURETOR

CARBURATEUR

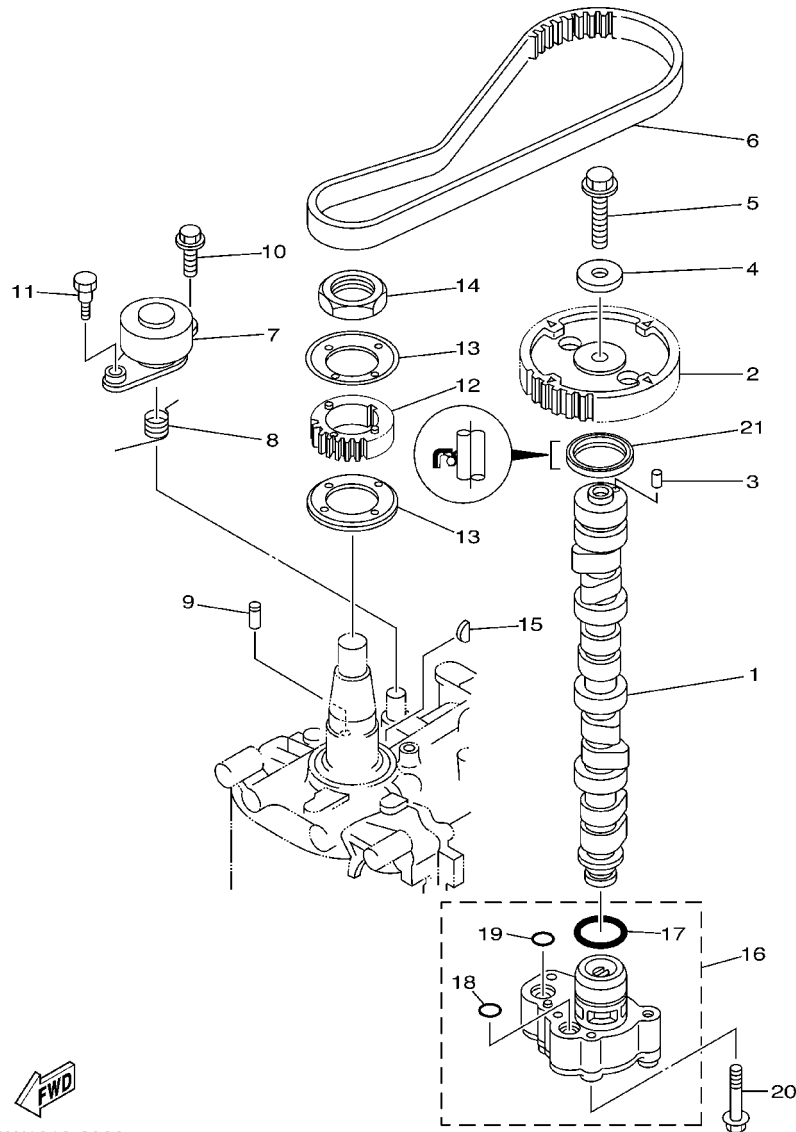


  
69W1010-2070

REF. NO.	PART NO. NO. PIECES	DESCRIPTION DESCRIPTION	F60A	F40C	REMARKS REMARQUES
27	98980-04006	.SCREW, BIND .VIS	4	4	
28	69W-24311-00	.PIPE, FUEL 1 .DURITE A ESSENCE	2	2	#1,3
29	62Y-14398-30	.GASKET .JOINT	2	2	#1,3
30	62Y-14567-30	.SCREW .VIS	2	2	#1
	62Y-14567-40	.SCREW .VIS	2	2	#3
31	69W-14380-01	.PRIME STARTER ASSY .DEMARREUR D'AMARCAGE ENS.	1	1	#1
	69W-14380-11	.PRIME STARTER ASSY .DEMARREUR D'AMARCAGE ENS.	1	1	#3
32	62Y-14227-00	.WASHER .RONDELLE	4	4	
33	62Y-24313-90	.PIPE 3 .DURITE 3	1	1	#3
34	62Y-14597-00	.WASHER .RONDELLE	1	1	#4
35	664-14327-01	.SCREW .VIS	1	1	#4
36	69W-14212-00	.SPRING, PILOT ADJUSTING .RESSORT, VIS DE RALENTI	2	2	#4
37	69W-14321-00	.SCREW, THROTTLE .VIS, ACCELERATEUR	2	2	#4
38	69W-14115-00	.PLUG, SCREW .PLOT DE VIS	4	4	
39	90430-08209	.GASKET .JOINT	4	4	

FIG. 8 OIL PUMP

POMPE A HUILE



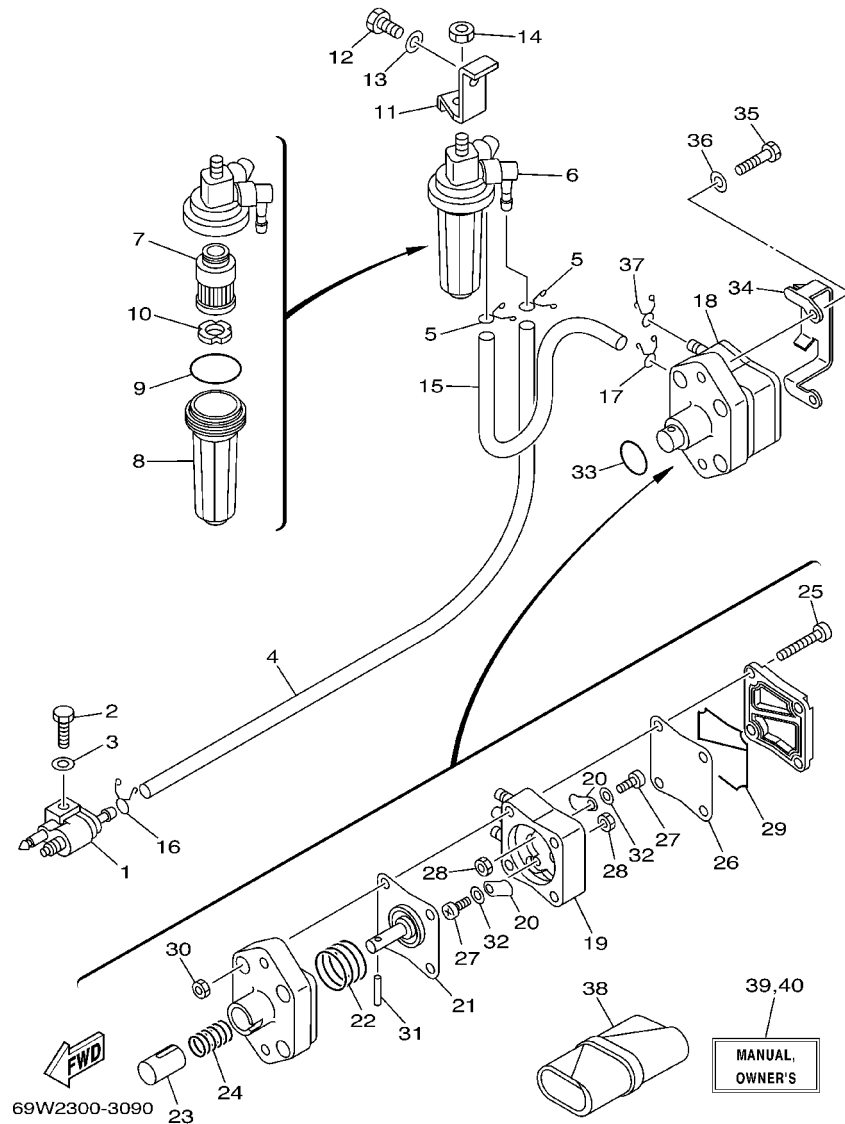
REF. NO.	PART NO. NO. PIECES	DESCRIPTION DESCRIPTION	F60A	F40C	REMARKS REMARQUES
1	62Y-12171-00	CAMSHAFT 1 ARBRE A CAMES 1	1	1	
2	62Y-11537-10	GEAR, DRIVEN PIGNON SECONDAIRE	1	1	
3	93605-14143	PIN, DOWEL AXE	1	1	
4	90201-10M06	WASHER, PLATE RONDELLE, PLATE	1	1	
5	95895-10040	BOLT, FLANGE BOULON	1	1	
6	62Y-46241-00	BELT COURROIE	1	1	
7	62Y-11590-10	TENSIONER ASSY TENDEUR (ENS.)	1	1	
8	90508-20018	SPRING, TORSION RESSORT, TORSION	1	1	
9	90249-07M29	PIN GOUPILLE	1	1	
10	95895-08020	BOLT, FLANGE BOULON	1	1	
11	90109-06M64	BOLT BOULON	1	1	
12	62Y-11536-10	GEAR, DRIVE ENGRENAGE, MENANT	1	1	
13	62Y-11557-00	WASHER 1 RONDELLE 1	2	2	
14	90170-35M32	NUT ECROU	1	1	
15	90280-04M06	KEY, WOODRUFF CLAVETTE, DEMI-LUNE	1	1	
16	69W-13300-00	OIL PUMP ASSY POMPE A HUILE COMPLET	1	1	
17	93210-33MH2	.O-RING .JOINT TORIQUE	1	1	
18	93210-12MG9	.O-RING .JOINT TORIQUE	1	1	
19	93210-14515	.O-RING .JOINT TORIQUE	1	1	
20	90119-06025	BOLT, WITH WASHER BOULON, AVEC RONDELLE	4	4	
21	93102-37M40	OIL SEAL JOINT SPY	1	1	



69W1010-2080

FIG. 9 FUEL

CARBURANT

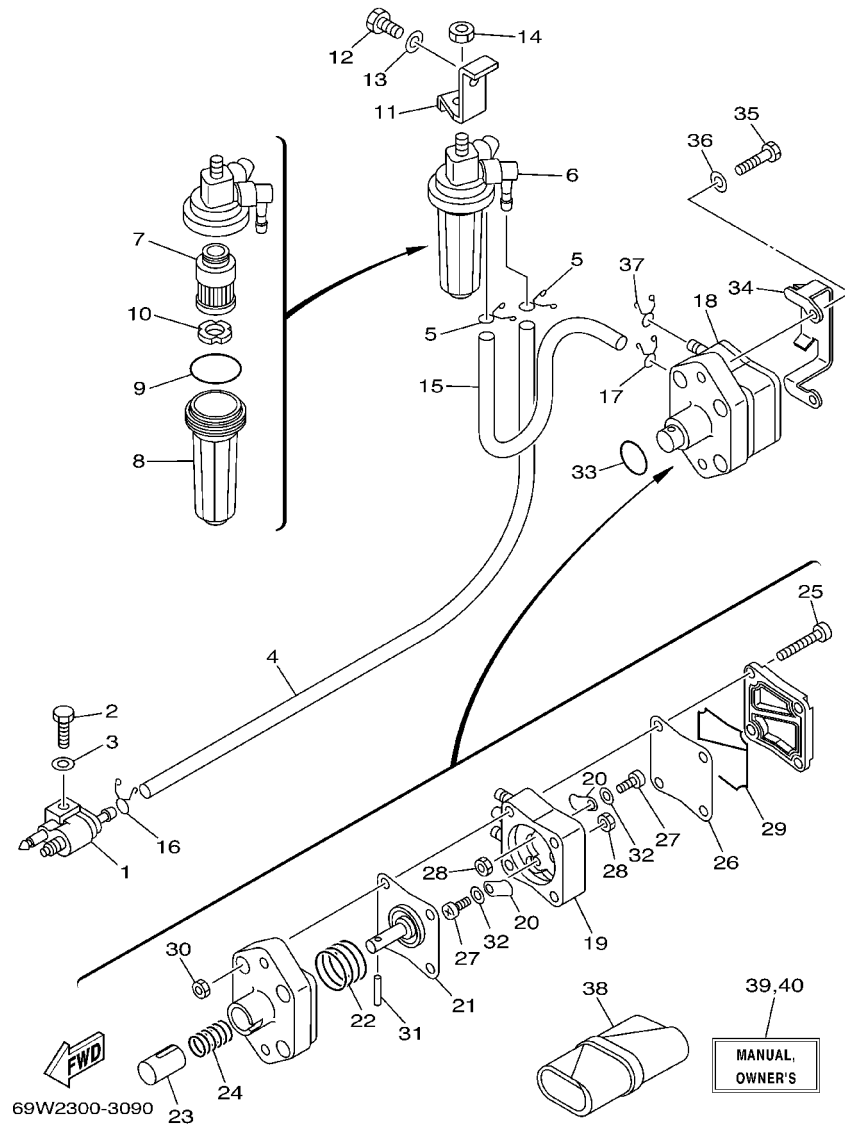


REF. NO.	PART NO. NO. PIECES	DESCRIPTION DESCRIPTION	F60A	F40C	REMARKS REMARQUES
1	6G1-24304-02	FUEL PIPE JOINT COMP. 1 DURITE RACCORDEMT. A ESSENCE	1	1	
2	97095-06025	BOLT BOULON	1	1	
3	92995-06600	WASHER RONDELLE	1	1	
4	90445-10020	HOSE DURITE	1	1	
5	90467-09M17	CLIP JONC	2	2	
6	64J-24560-00	FILTER ASSY ENS FILTRE	1	1	
7	68V-24563-00	.ELEMENT, FILTER .ELEMENT, FILTRE	1	1	
8	68V-24521-00	.CUP, FILTER .CUVETTE, FILTRE	1	1	
9	93210-32738	.O-RING .JOINT TORIQUE	1	1	
10	68V-24469-00	.FLOAT, WATER LEVEL .FLOTTEUR	1	1	
11	62Y-24566-00	BRACKET, FILTER SUPPORT, FILTRE	1	1	
12	97095-08014	BOLT BOULON	1	1	
13	92995-08600	WASHER RONDELLE	1	1	
14	95380-08600	NUT ECROU	1	1	
15	90445-10M48	HOSE (L205) DURITE (L205)	1	1	
16	90467-09M17	CLIP JONC	1	1	
17	90467-10M04	CLIP JONC	1	1	
18	62Y-24410-03	FUEL PUMP ASSY POMPE A ESSENCE	1	1	
19	62Y-24413-01	.BODY 2 .CORPS 2	1	1	
20	62Y-24421-01	.VALVE, CHECK .SOUPAPE, RETENUE	2	2	
21	62Y-24411-02	.DIAPHRAGM .DIAPHRAGME	1	1	
22	62Y-24423-00	.SPRING, DIAPHRAGM .RESSORT, DIAPHRAGME	1	1	
23	62Y-13131-01	.PLUNGER .PLONGEUR	1	1	
24	62Y-24454-00	.SPRING .RESSORT	1	1	
25	62Y-24444-01	.SCREW .VIS	4	4	
26	62Y-24471-00	.DIAPHRAGM .DIAPHRAGME	1	1	
27	6A0-14325-00	.SCREW, PAN HEAD .VIS TETE CONIQUE	2	2	



FIG. 9 FUEL

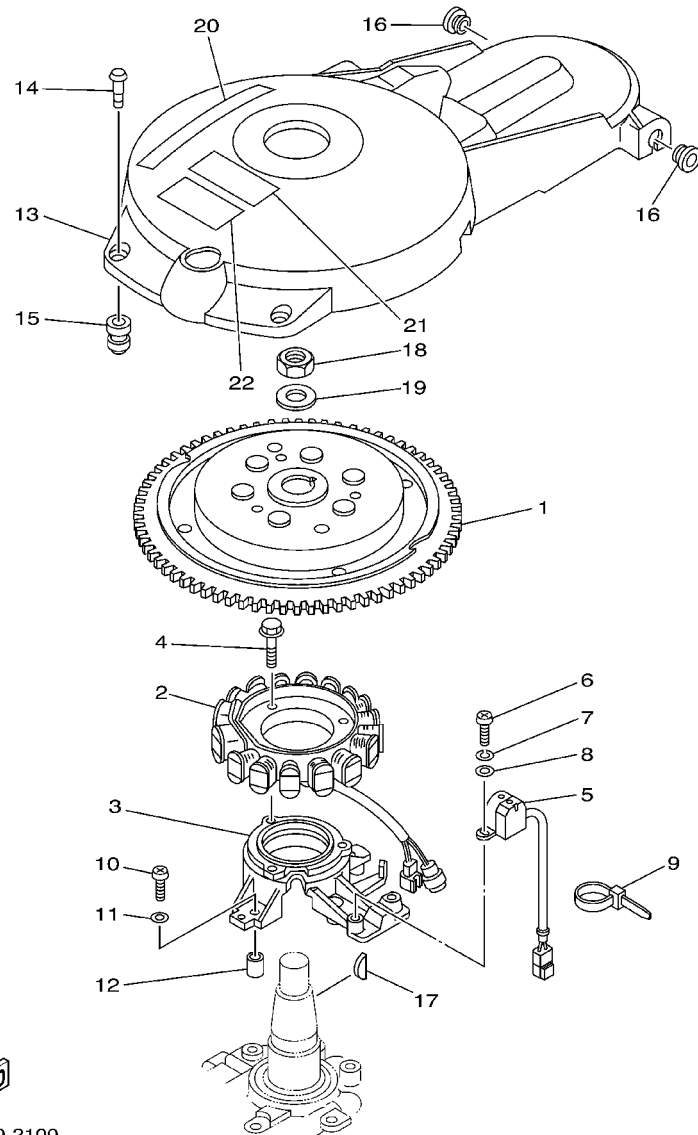
CARBURANT



REF. NO.	PART NO. NO. PIECES	DESCRIPTION DESCRIPTION	F60A	F40C	REMARKS REMARQUES
28	95380-03600	.NUT .ECROU	2	2	
29	62Y-24452-00	.PACKING .JOINT	1	1	
30	95380-05600	.NUT .ECROU	4	4	
31	62Y-24374-01	.PIN .PIN	1	1	
32	62Y-24422-00	.PLATE .PLAQUETTE	2	2	
33	93210-24M79	O-RING JOINT TORIQUE	1	1	
34	65W-24474-00	COVER COUVERCLE	1	1	
35	97095-06030	BOLT BOULON	2	2	
36	92995-06600	WASHER RONDELLE	2	2	
37	90467-10M04	CLIP JONC	2	2	
38	62Y-28100-00	TOOL KIT TROUSSE A OUTILS	1	1	
39	62Y-28199-7C-A0	MANUAL,OWNER'S MANUEL D'UTILISATION	1	1	UR (E,F,S)
	62Y-28199-7C-B0	MANUAL,OWNER'S MANUEL D'UTILISATION	1	1	UR (D,NL,I)
40	62Y-28199-8C-A0	MANUAL,OWNER'S MANUEL D'UTILISATION	1	1	UR (DK,P,GR)
	62Y-28199-8C-B0	MANUAL,OWNER'S MANUEL D'UTILISATION	1	1	UR (N,S,SS)

FIG. 10 GENERATOR

GENERATRICE

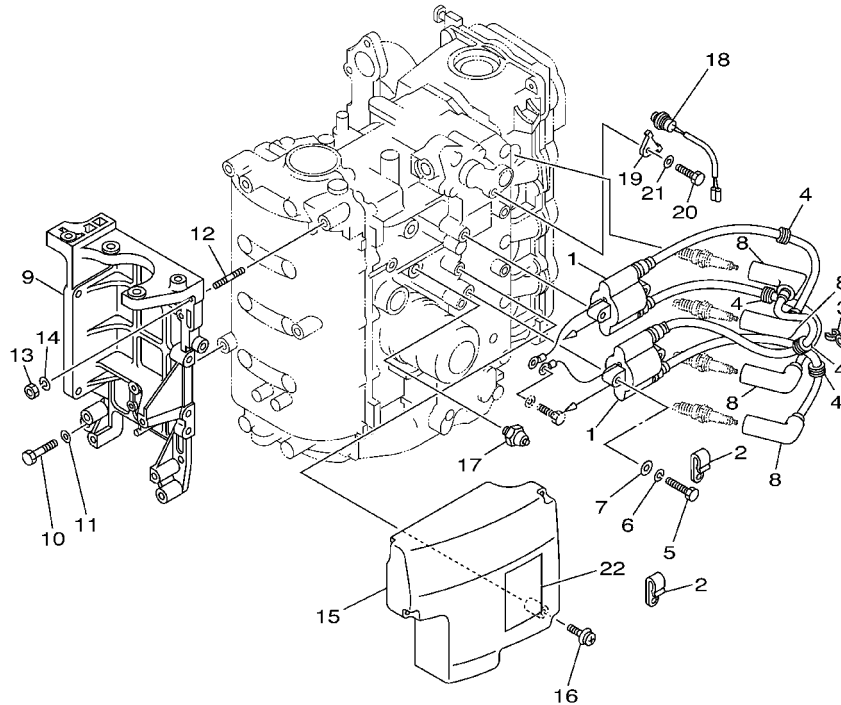


REF. NO.	PART NO. NO. PIECES	DESCRIPTION DESCRIPTION	F60A	F40C	REMARKS REMARQUES
1	69W-85550-10	ROTOR ASSY ROTOR CPLT	1	1	
2	64J-85510-00	STATOR ASSY STATOR CPLT	1	1	
3	62Y-85561-00-94	BASE, MAGNETO BASE, MAGNETO	1	1	
4	95023-06025	BOLT BOULON, A COLLERETTE	3	3	
5	62Y-85580-00	COIL, PULSER BOBINE, PULSEUR	1	1	
6	97880-05012	SCREW, PAN HEAD VIS, TETE TRONCONIQUE	2	2	
7	92990-05100	WASHER, SPRING RONDELLE, GROWER	2	2	
8	92990-05600	WASHER, PLATE RONDELLE, PLATE	2	2	
9	90465-13M97	CLAMP BRIDE	1	1	
10	97880-06025	SCREW, PAN HEAD VIS, TETE TRONCONIQUE	4	4	
11	92990-06600	WASHER, PLATE RONDELLE, PLATE	4	4	
12	99530-08012	PIN, DOWEL GOUJON, D'ASSEMBLAGE	2	2	
13	62Y-81337-11	COVER, FLYWHEEL COUVERCLE, VOLANT	1	1	
14	6K7-81338-01	CLAMP, LEAD COLLIER, FIL	2	2	
15	663-82317-01	DAMPER, IGNITION COIL AMORTISSEUR, BOBINE D'ALLUM	2	2	
16	90480-12072	GROMMET PASSE-FIL	2	2	
17	6H4-11545-00	KEY, WOODRUFF CLAVETTE, DEMI-LUNE	1	1	
18	90170-20137	NUT ECROU	1	1	
19	90201-21M18	WASHER, PLATE RONDELLE, PLATE	1	1	
20	62Y-13437-61	MARK, CAUTION MAKER	1	1	
21	6A1-83625-41	MARK 5 ETIQUETTE 5	1	1	
22	6A1-83625-51	MARK 5 ETIQUETTE 5	1	1	

FWD  
69W1300-2100

FIG. 11 ELECTRICAL 1

PARTIE ELECTRIQUE 1



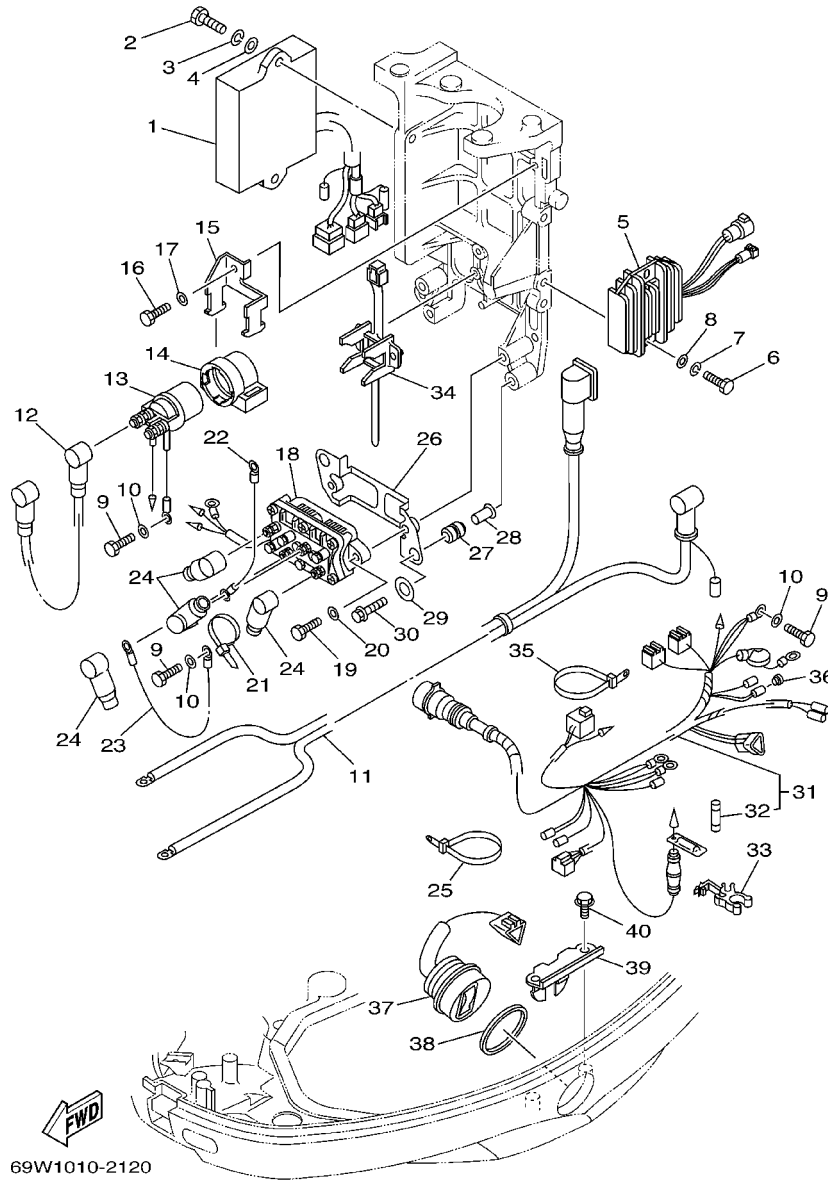
REF. NO.	PART NO. NO. PIECES	DESCRIPTION DESCRIPTION	F60A	F40C	REMARKS REMARQUES
1	62Y-85570-00	IGNITION COIL ASSY BOBINE D'ALLUMAGE (ENS.)	2	2	
2	90465-06M90	CLAMP BRIDE	2	2	
3	90464-07M41	CLAMP BRIDE	1	1	
4	90480-25161	GROMMET PASSE-FIL	4	4	
5	97095-06030	BOLT BOULON	4	4	
6	92995-06100	WASHER, SPRING RONDELLE, GROWER	4	4	
7	92995-06600	WASHER RONDELLE	4	4	
8	6G8-82370-30	PLUG CAP ASSY ANTIPARASITE	4	4	
9	62Y-81822-01-94	BRACKET, STARTING MOTOR SUPPORT, DEMARREUR ELECTRIQUE	1	1	
10	97095-08035	BOLT BOULON	3	3	
11	92995-08600	WASHER RONDELLE	3	3	
12	90116-08M14	BOLT, STUD GOUJON	1	1	
13	95380-08600	NUT ECROU	1	1	
14	92990-08100	WASHER, SPRING RONDELLE, GROWER	1	1	
15	62Y-85599-00	COVER COUVERCLE	1	1	
16	90159-06M08	SCREW, WITH WASHER VIS, AVEC RONDELLE	3	3	
17	64J-82504-00	OIL PRESSURE SWITCH ASSY CONTACTEUR DE PRESSION D'HUILE	1	1	
18	62Y-82560-01	THERMO SWITCH ASSY THERMO-CONTACT COMPLET	1	1	
19	6E9-82588-00	PLATE PLAQUE	1	1	
20	97095-06012	BOLT BOULON	1	1	
21	92995-06600	WASHER RONDELLE	1	1	
22	62Y-83626-00	MARK 6 MARK 6	1	1	



69W1010-2110

FIG. 12 ELECTRICAL 2

PARTIE ELECTRIQUE 2

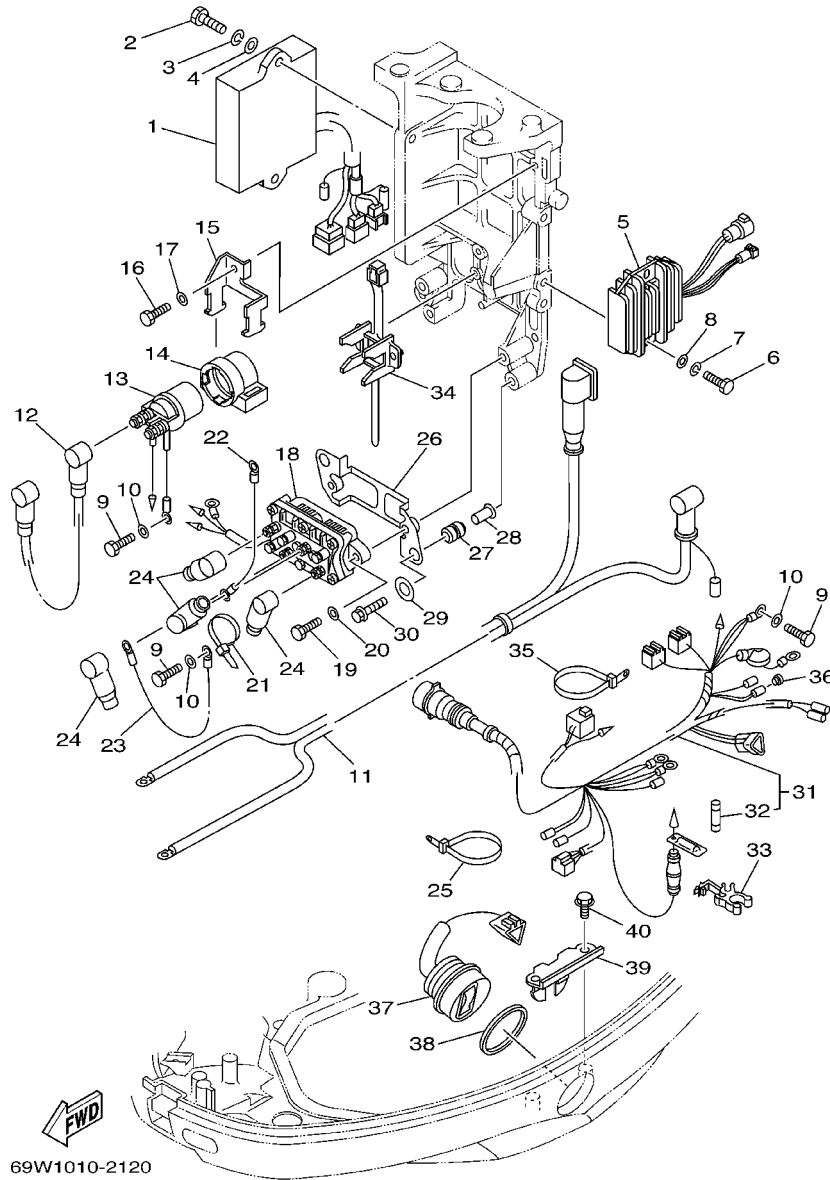


69W1010-2120

REF. NO.	PART NO. NO. PIECES	DESCRIPTION DESCRIPTION	F60A	F40C	REMARKS REMARQUES
1	69W-85540-00	C.D.I. UNIT ASSY BLOC C.D.I.	1	1	
2	97095-06020	BOLT BOULON	2	2	
3	92995-06100	WASHER, SPRING RONDELLE, GROWER	2	2	
4	92995-06600	WASHER RONDELLE	2	2	
5	64J-81960-00	RECTIFIER & REGULATOR ASSY REDRESSEUR REGULATEUR CPLT	1	1	
6	97095-06025	BOLT BOULON	2	2	
7	92995-06100	WASHER, SPRING RONDELLE, GROWER	2	2	
8	92995-06600	WASHER RONDELLE	2	2	
9	97095-06012	BOLT BOULON	3	3	
10	92995-06600	WASHER RONDELLE	3	3	
11	62Y-82105-00	WIRE HARNESS FAISCEAU DE FILS	1	1	
12	6E5-82117-01	WIRE, LEAD FIL	1	1	
13	6G1-81941-10	STARTER RELAY ASSY LANCEUR RELAIS (ENS.)	1	1	
14	6G1-81952-00	HOLDER, RELAY SUPPORT, RELAIS	1	1	
15	6L2-81945-00	PLATE, SWITCH FITTING PLAQUE, FIXATION DU RELAIS	1	1	
16	97095-06014	BOLT BOULON	1	1	
17	92995-06600	WASHER RONDELLE	1	1	
18	6H1-81950-00	RELAY ASSY RELAIS COMPLET	1	1	
19	97095-06020	BOLT BOULON	2	2	
20	92995-06600	WASHER RONDELLE	2	2	
21	90465-13M11	CLAMP BRIDE	1	1	
22	6H2-81949-01	WIRE, LEAD FIL	1	1	
23	61A-81949-00	WIRE, LEAD FIL	1	1	
24	682-82119-01	COVER, LEAD WIRE GARNITURE, FIL	4	4	
25	90465-13M24	CLAMP BRIDE	1	1	
26	62Y-81948-00	BRACKET JOINT TORIQUE	1	1	
27	6A0-82317-00	DAMPER, IGNITION COIL AMORTISSEUR, BOBINE D'ALLUM	2	2	

FIG. 12 ELECTRICAL 2

PARTIE ELECTRIQUE 2

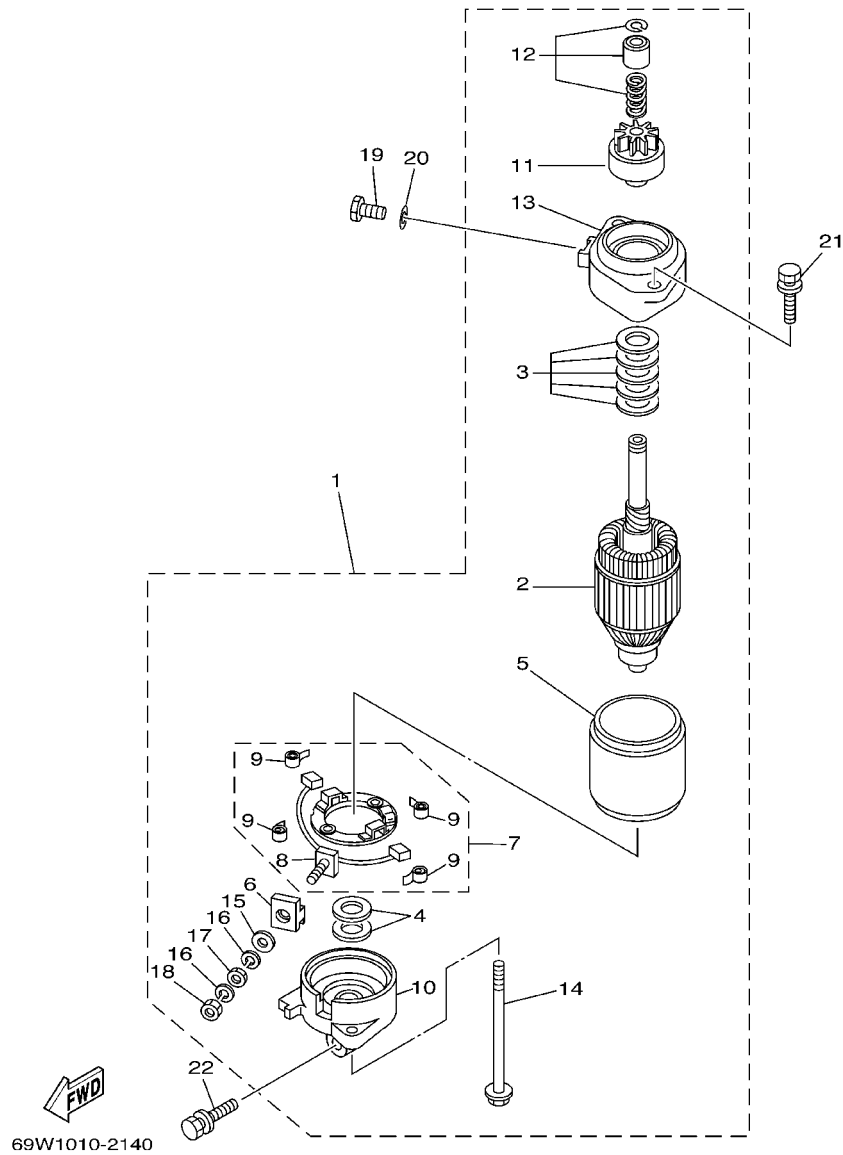


69W1010-2120

REF. NO.	PART NO. NO. PIECES	DESCRIPTION DESCRIPTION	F60A	F40C	REMARKS REMARQUES
28	624-42542-00	PIPE TUYAU	2	2	
29	90201-12M16	WASHER, PLATE RONDELLE, PLATE	2	2	
30	95895-06025	BOLT, FLANGE BOULON	2	2	
31	69W-82590-00	WIRE HARNESS ASSY FAISCEAU DE FILS COMPLET	1	1	
32	663-82151-00	.FUSE (12V-20A) .FUSIBLE (12V-20A)	1	1	
33	6G5-82152-00	HOLDER, FUSE SUPPORT, FUSIBLE	1	1	
34	688-82594-00	CLAMP BRIDE	1	1	
35	90465-13M24	CLAMP BRIDE	1	1	
36	703-82119-00	COVER, LEAD WIRE GARNITURE, FIL	2	2	
37	63D-82563-10	TRIM & TILT SWITCH ASSY INCLINER ET PARER COMMUTATEUR	1	1	
38	6E5-82587-00	GASKET JOINT	1	1	
39	62Y-83614-00	BRACKET SUPPORT	1	1	
40	90109-06M86	BOLT BOULON	2	2	

FIG. 13 STARTING MOTOR

DEMARREUR ELECTRIQUE



REF. NO.	PART NO. NO. PIECES	DESCRIPTION DESCRIPTION	F60A	F40C	REMARKS REMARQUES
1	69W-81800-00	STARTING MOTOR ASSY DEMARREUR ELECTRIQUE COMPLET	1	1	
2	6N7-81850-10	.ARMATURE ASSY .INDUIT	1	1	
3	61A-81809-00	.WASHER KIT .JEU DE RONDELLES	1	1	
4	61A-81824-00	.WASHER 2 .RONDELLE 2	2	2	
5	6N7-81810-00	.STATOR ASSY .STATOR COMPLET	1	1	
6	6K7-8182G-10	.BUSH, TERMINAL .DOUILLE	1	1	
7	6N7-81840-00	.BRUSH HOLDER ASSY .SUPPORT DE CHARBON	1	1	
8	6N7-81801-00	..BRUSH SET ..CHARBON	1	1	
9	6N7-81813-00	..SPRING, BRUSH ..RESSORT, DE CHARBON	4	4	
10	6N7-81820-00	.REAR BRACKET ASSY .SUPPORT ARRIERE COMPLET	1	1	
11	69W-81807-00	.GEAR ASSY, STARTING MOTOR .PIGNON, DEMARREUR ELECTRIQUE	1	1	
12	6N7-81857-00	.RETAINER .ARRETOIR	1	1	
13	6N7-81830-00	.FRONT BRACKET ASSY .SUPPORT AVANT	1	1	
14	6K7-81826-10	.BOLT .BOULON	2	2	
15	6E5-8182E-10	.WASHER .RONDELLE	1	1	
16	6E5-8182F-10	.WASHER .RONDELLE	2	2	
17	6E5-8182A-10	.NUT .ECROU	1	1	
18	6E5-8182K-10	.NUT .ECROU	1	1	
19	97095-08016	BOLT BOULON	1	1	
20	92995-08600	WASHER RONDELLE	1	1	
21	90119-08M76	BOLT, WITH WASHER BOULON, AVEC RONDELLE	2	2	
22	90119-08M77	BOLT, WITH WASHER BOULON, AVEC RONDELLE	1	1	

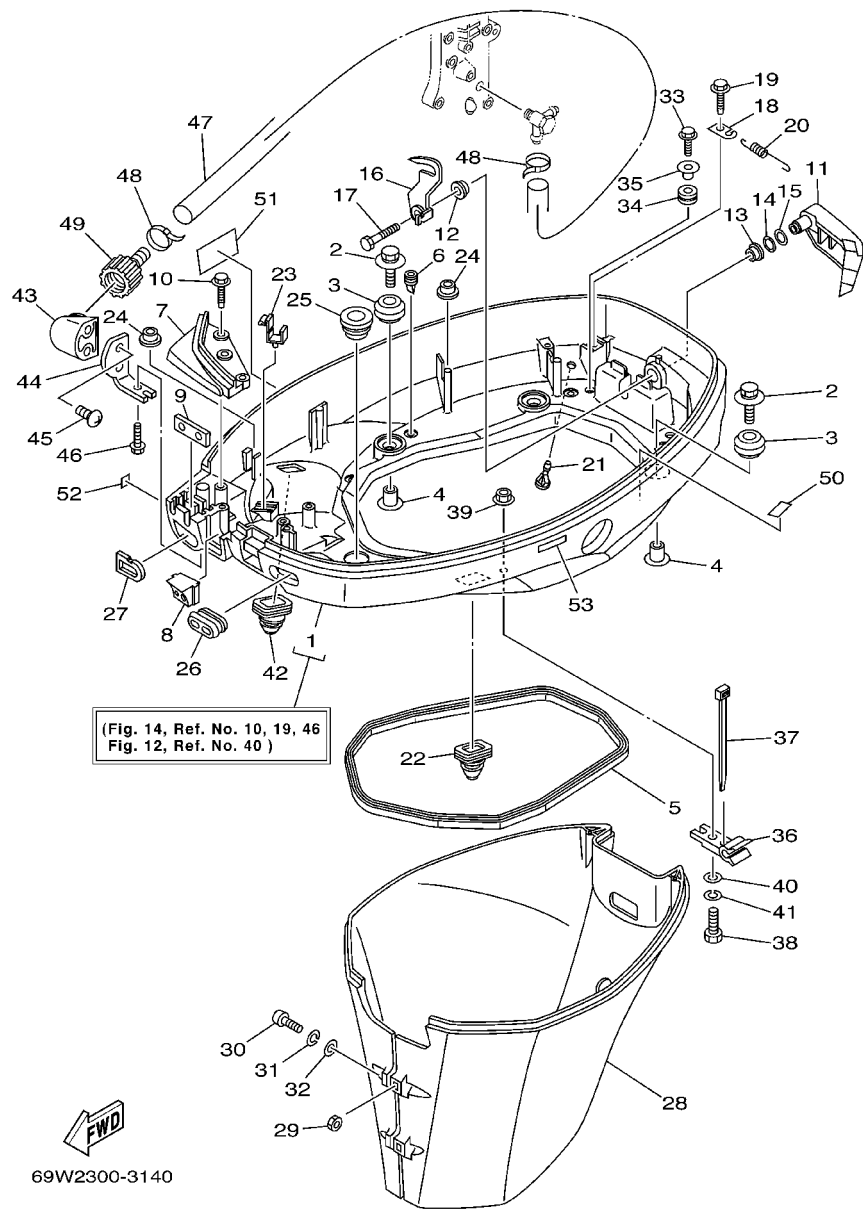
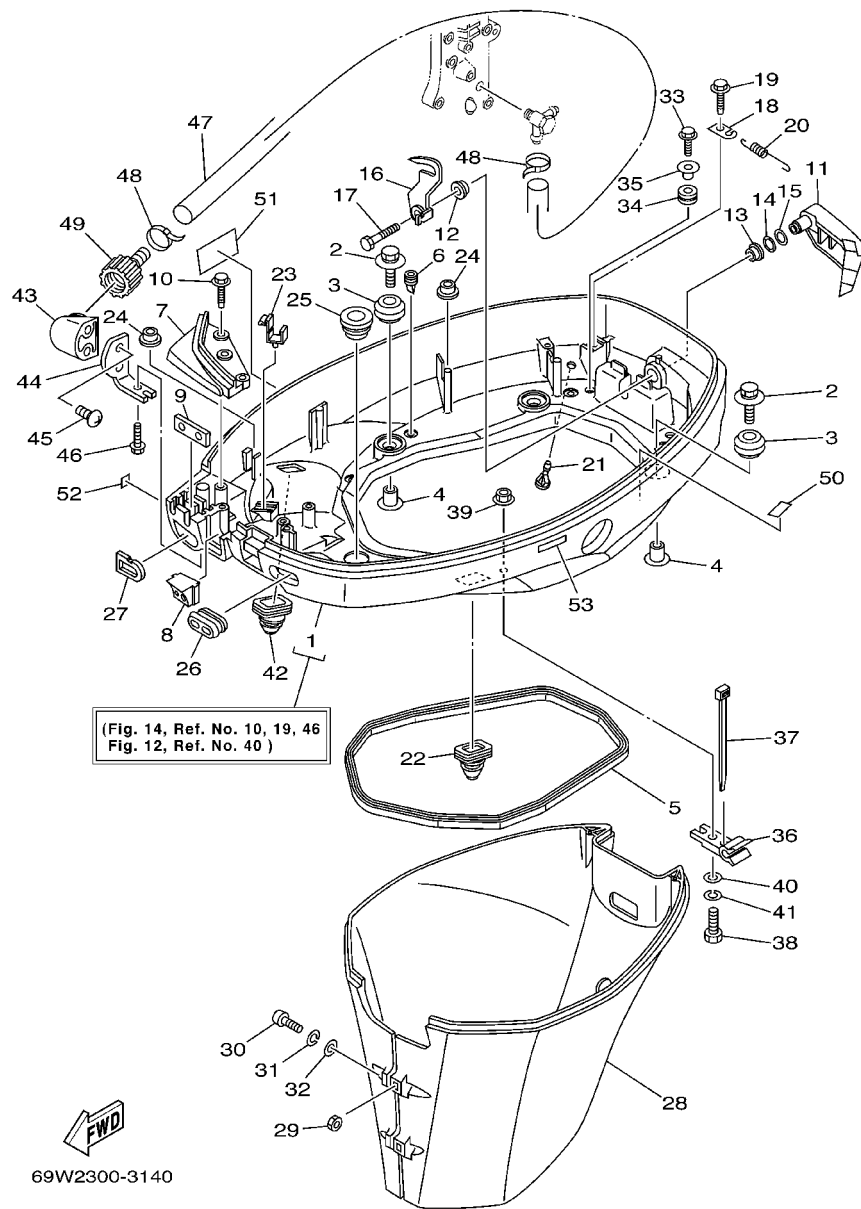


FIG. 14 BOTTOM COWLING

CAPOT INFERIEUR

REF. NO.	PART NO. NO. PIECES	DESCRIPTION DESCRIPTION	F60A	F40C	REMARKS REMARQUES
1	67C-42710-12-4D	BOTTOM COWLING ASSY ENS. EMBASE	1	1	WITH TAPPING BOLT
2	90119-06M08	BOLT, WITH WASHER BOULON, AVEC RONDELLE	4	4	
3	90480-09M12	GROMMET PASSE-FIL	4	4	
4	90387-06060	COLLAR COLLERETTE	4	4	
5	62Y-42716-00	RUBBER, SEAL 1 JOINT EN CAOUTCHOUC 1	1	1	
6	65W-42717-00	RUBBER, SEAL 2 JOINT EN CAOUTCHOUC 2	4	4	
7	67C-42738-00-4D	PLATE, FITTING ETRIER	1	1	
8	62Y-42725-30	GROMMET PASSE-FIL	1	1	
9	62Y-42727-00	GROMMET PASSE-FIL	1	1	
10	90109-06M81	BOLT BOULON	3	3	
11	67C-42815-00-4D	LEVER, CLAMP LEVIER, PRESSE	1	1	
12	90386-12M37	BUSH DOUILLE	1	1	
13	90386-12MA2	BUSH DOUILLE	1	1	
14	90206-12052	WASHER, WAVE RONDELLE, ONDULEE	1	1	
15	90201-12M07	WASHER, PLATE RONDELLE, PLATE	1	1	
16	67C-42816-01	LEVER, CLAMP LEVIER, PRESSE	1	1	
17	97095-06012	BOLT BOULON	1	1	
18	66T-43144-00	HOOK, SPRING CROCHET	1	1	
19	90109-06M86	BOLT BOULON	1	1	
20	90506-18M40	SPRING, TENSION RESSORT, TENSION	1	1	
21	6H3-44391-01	NIPPLE, HOSE RACCORD D'ESSENCE	1	1	
22	688-42726-10	GROMMET PASSE-FIL	1	1	
23	90464-09M13	CLAMP BRIDE	1	1	
24	6E7-82317-00	DAMPER, IGNITION COIL AMORTISSEUR, BOBINE D'ALLUM	2	2	
25	68U-42727-00	GROMMET PASSE-FIL	1	1	
26	6H3-42727-00	GROMMET PASSE-FIL	1	1	
27	61N-24329-00	SEAL JOINT	1	1	



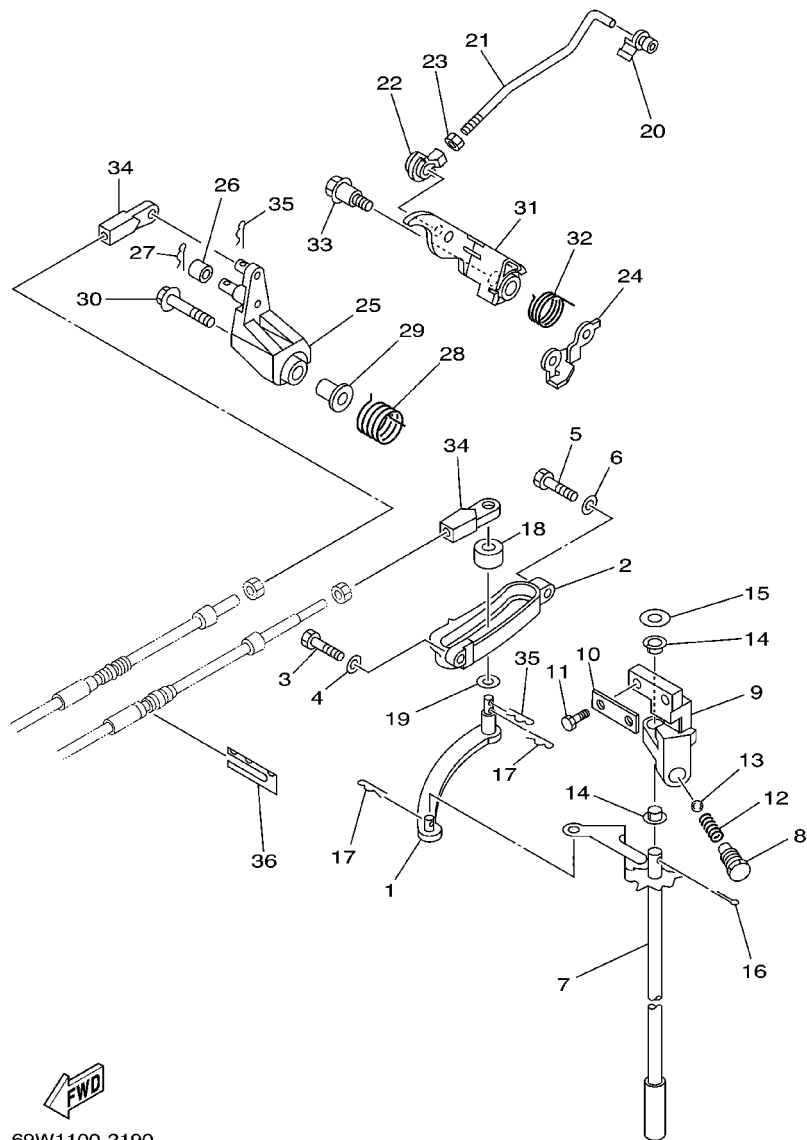
69W2300-3140

FIG. 14 BOTTOM COWLING

CAPOT INFÉRIEUR

REF. NO.	PART NO. NO. PIECES	DESCRIPTION DESCRIPTION	F60A	F40C	REMARKS REMARQUES
28	67C-42741-10-4D	APRON CAPOT LATERAL	1	1	
29	95380-06600	NUT, HEXAGON ECROU	2	2	
30	97880-06025	SCREW, PAN HEAD VIS, TÊTE TRONCONIQUE	2	2	
31	92990-06100	WASHER, SPRING RONDELLE, GROWER	2	2	
32	92990-06600	WASHER, PLATE RONDELLE, PLATE	2	2	
33	90109-06M80	BOLT BOULON	2	2	
34	90480-13M24	GROMMET PASSE-FIL	2	2	
35	90387-06M43	COLLAR COLLERETTE	2	2	
36	90464-09M49	CLAMP BRIDE	1	1	
37	90465-11M10	CLAMP BRIDE	1	1	
38	90101-06020	BOLT BOULON	1	1	
39	90179-06M28	NUT ECROU	1	1	
40	92990-06600	WASHER, PLATE RONDELLE, PLATE	1	1	
41	92995-06100	WASHER, SPRING RONDELLE, GROWER	1	1	
42	65W-42724-10	GROMMET PASSE-FIL	1	1	FOR FLUSHING KIT
43	68T-12572-00	ADAPTER ADAPTATEUR	1	1	FLUSHING KIT
44	69W-12535-00	PLATE PLAQUE	1	1	FLUSHING KIT
45	90167-06002	SCREW, TAPPING VIS, TÊTE FRAISÉE	2	2	FLUSHING KIT
46	90109-06M80	BOLT BOULON	1	1	FLUSHING KIT
47	67C-24312-00	PIPE 2 DURITE 2	1	1	FLUSHING KIT
48	90465-11M10	CLAMP BRIDE	2	2	FLUSHING KIT
49	6R3-12580-00	JOINT ASSY ARTICULER (ENS.)	1	1	FLUSHING KIT
50	69W-82377-00	LABEL ÉTIQUETTE	1	1	
51	62Y-13444-50	MARK MARKER	1	1	
52	6A1-28176-00	LABEL, CAUTION ÉTIQUETTE, RECOMMANDATION	1	1	
53	6E3-8257H-00	PLATE, MARK PLAQUE, ADHÉSIF	1	1	





69W1100-2190

FIG. 15 CONTROL

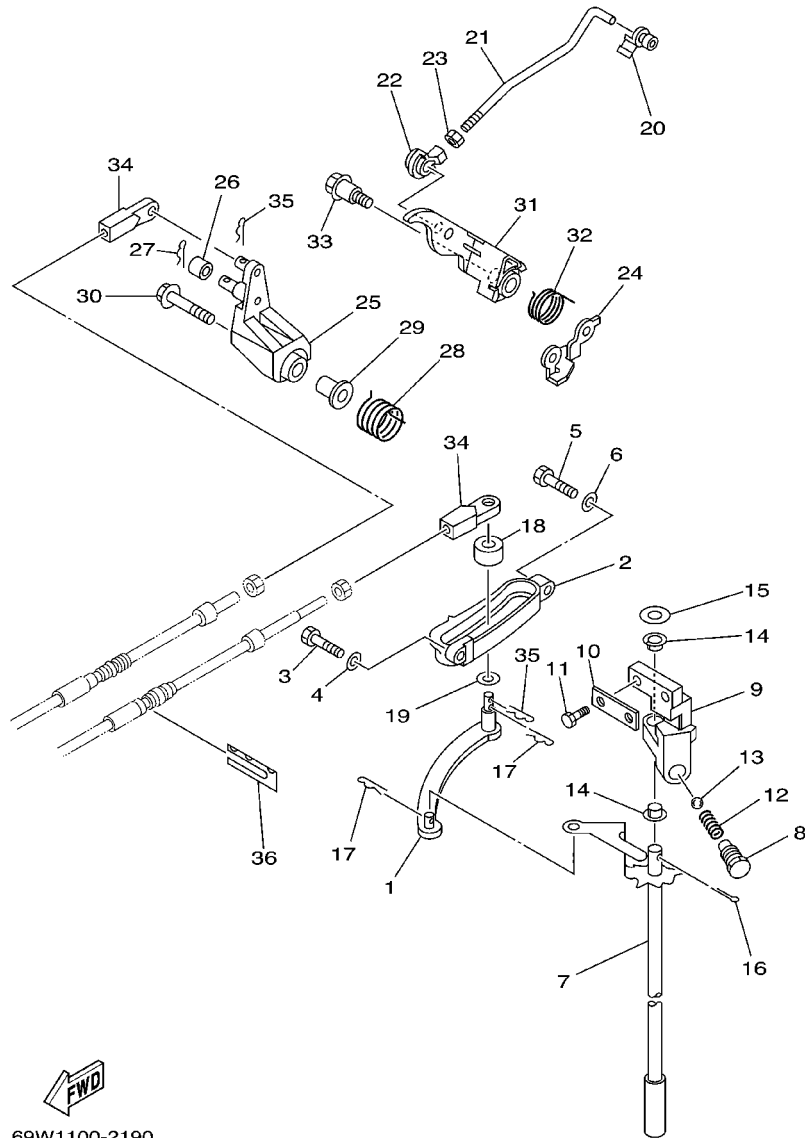
COMMANDE

REF. NO.	PART NO. NO. PIECES	DESCRIPTION DESCRIPTION	F60A	F40C	REMARKS REMARQUES
1	69W-44121-00	LEVER, SHIFT ROD LEVIER, TIGE D'INVERSION	1	1	
2	62Y-44117-01-4D	BRACKET SUPPORT	1	1	
3	97095-06020	BOLT BOULON	1	1	
4	92995-06600	WASHER RONDELLE	1	1	
5	97095-06025	BOLT BOULON	1	1	
6	92995-06600	WASHER RONDELLE	1	1	
7	62Y-44120-01	HANDLE GEAR SHIFT ASSY LEVIER D'EMBRAYAGE	1	1	
8	62Y-42715-01	BUSHING COUSSINET	1	1	
9	62Y-44118-00	BRACKET SUPPORT	1	1	
10	62Y-44112-00	STAY, HANDLE GEAR SHIFT PLAQUE	1	1	
11	97095-06020	BOLT BOULON	2	2	
12	90501-12082	SPRING, COMPRESSION RESSORT, COMPRESSION	1	1	
13	93501-04M02	BALL BILLE	1	1	
14	90386-90M90	BUSH DOUILLE	2	2	
15	90201-10M20	WASHER, PLATE RONDELLE, PLATE	1	1	
16	91490-20015	PIN, COTTER GOUPILLE	1	1	
17	90468-18008	CLIP JONC	2	2	
18	688-44122-00	BUSHING, SHIFT ROD LEVER DOUILLE, LEVIER D'EMBRAYAGE	1	1	
19	90202-07M07	WASHER, PLATE RONDELLE, PLATE	1	1	
20	6F5-41237-00	JOINT, LINK RACCORD	1	1	
21	69W-41241-00	ROD, LINK BIELLE	1		
	60K-41241-00	ROD, LINK BIELLE		1	
22	662-41237-01	JOINT, LINK RACCORD	1	1	
23	95380-05700	NUT ECROU	1	1	
24	69W-42159-00	STAY SUPPORT	1	1	
25	62Y-42154-00	LEVER, THROTTLE CONTROL LEVIER DE COMMANDE D'AVANCE	1	1	
26	69W-42171-00	BUSHING COUSSINET	1	1	

D4

FIG. 15 CONTROL

COMMANDE

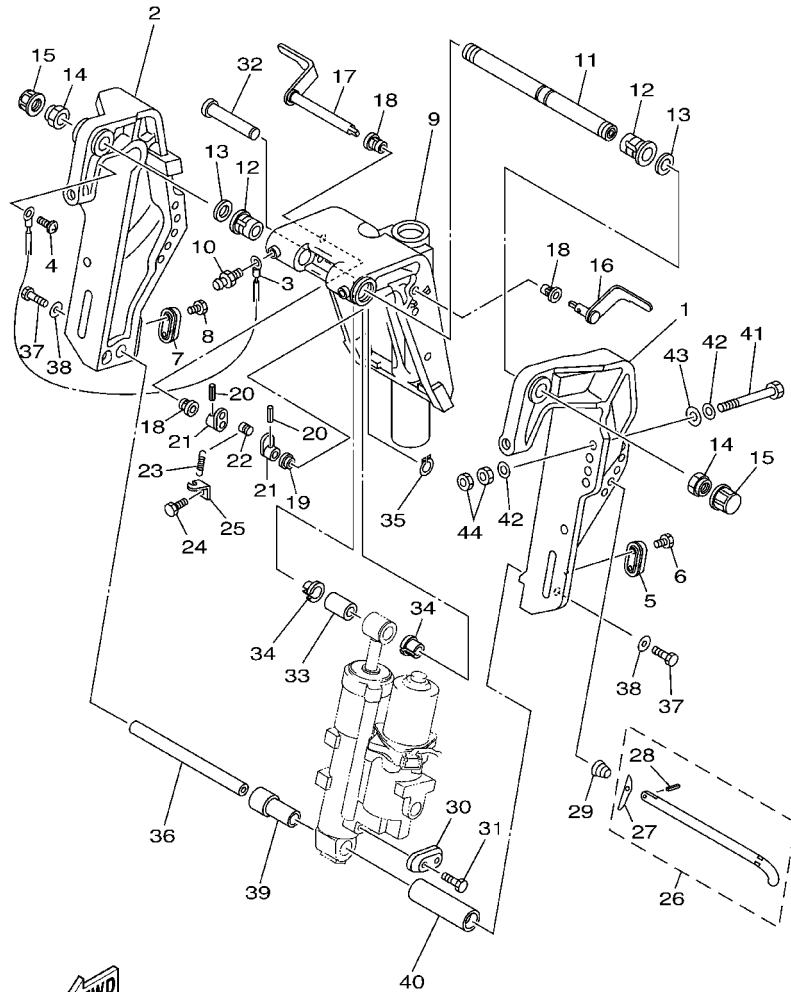


REF. NO.	PART NO. NO. PIECES	DESCRIPTION DESCRIPTION	F60A	F40C	REMARKS REMARQUES
27	91490-16010	PIN, COTTER GOUILLE	1	1	
28	62Y-44135-00	SPRING RESSORT	1	1	
29	90387-06M45	COLLAR COLLERETTE	1	1	
30	95895-06035	BOLT, FLANGE BOULON	1	1	
31	62Y-42335-20	LEVER, ACCEL. CONTROL LEVIER, ACCELERATION	1		
	60K-42335-00	LEVER, ACCEL. CONTROL LEVIER, ACCELERATION		1	
32	62Y-44116-01	SPRING RESSORT	1	1	
33	90109-06M30	BOLT BOULON	1	1	
34	69W-48344-00	CABLE END, REMOTE CONTROL CHAPE CABLE	2	2	
35	90468-18008	CLIP JONC	2	2	
36	62Y-48538-00	CLAMP, CABLE 1 COLLIER	1	1	

  
69W1100-2190

FIG. 16 BRACKET 1

SUPPORT 1

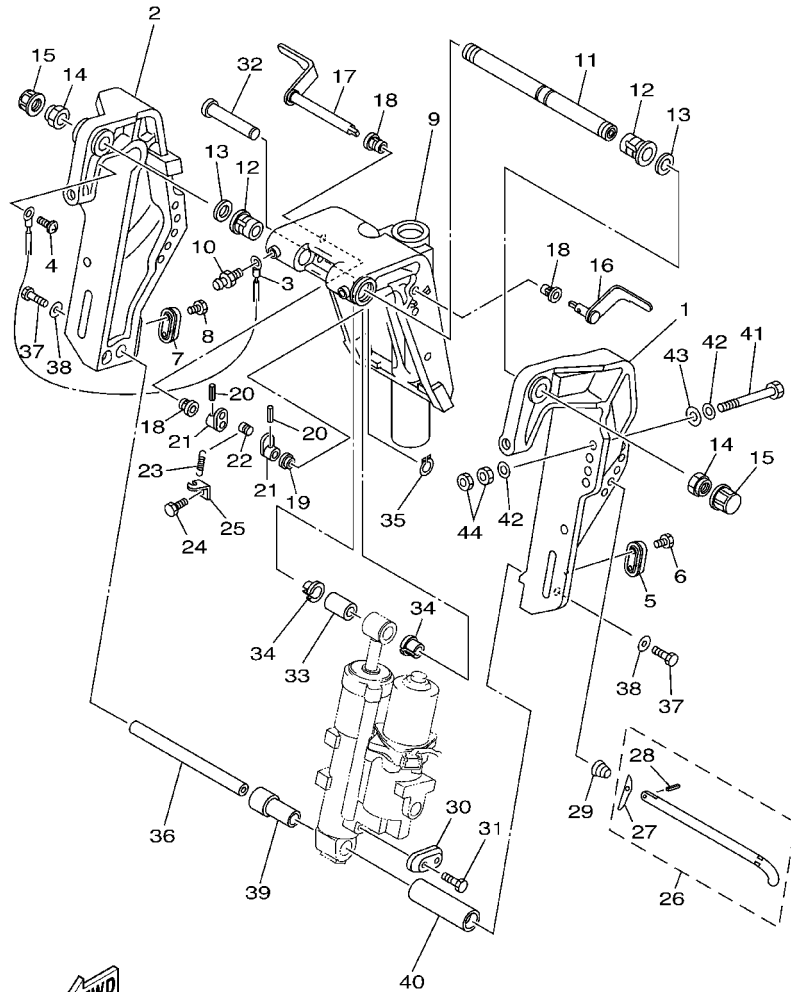


69W1010-2190

REF. NO.	PART NO. NO. PIECES	DESCRIPTION DESCRIPTION	F60A	F40C	REMARKS REMARQUES
1	69W-43111-00-4D	BRACKET, CLAMP PRESSE	1	1	
2	69W-43112-00-4D	BRACKET, CLAMP PRESSE	1	1	
3	63D-82148-00	WIRE, LEAD 4 FIL 4	1	1	
4	97885-06008	SCREW, PAN HEAD VIS, A ENCOCHE	1	1	
5	65W-45251-00	ANODE ANODE	1	1	
6	90101-06020	BOLT BOULON	2	2	
7	65W-45251-00	ANODE ANODE	1	1	
8	90101-06020	BOLT BOULON	2	2	
9	63D-43311-13-4D	BRACKET, SWIVEL 1 SUPPORT, PIVOT 1	1	1	
10	93700-06M03	NIPPLE, GREASE PION	3	3	
11	63D-43131-01	BOLT, CLAMP BRACKET BOULON, PRESSE	1	1	
12	90386-22M15	BUSH DOUILLE	2	2	
13	90201-22M03	WASHER, PLATE RONDELLE, PLATE	2	2	
14	90185-22M11	NUT, SELF-LOCKING ECROU, AUTO-BLOCANT	2	2	
15	6G5-43145-01	CAP, CLAMP BRACKET CAPUCHON, PRESSE	2	2	
16	6H5-43181-03	LEVER, TILT STOP LEVIER, VERROUILLAGE RELEVAGE	1	1	
17	6H5-43185-03	LEVER, TILT STOP LEVIER, VERROUILLAGE RELEVAGE	1	1	
18	90386-10M16	BUSH DOUILLE	3	3	
19	90386-10025	BUSH DOUILLE	1	1	
20	91690-30020	PIN, SPRING AGRAFFE	2	2	
21	6G5-43148-00	COLLAR, DISTANCE ENTRETOISE	2	2	
22	90249-06M19	PIN GOUPILLE	1	1	
23	90506-14M24	SPRING, TENSION RESSORT, TENSION	1	1	
24	97095-06010	BOLT BOULON	1	1	
25	6G5-43144-00	HOOK, SPRING CROCHET	1	1	
26	688-43160-01	TILT ROD ASSY BROCHE D'INCLINAISON (ENS.)	1	1	
27	688-43165-00	.PLATE, TILT LOCK .TAQUET, BROCHE INCLINAISON	1	1	

FIG. 16 BRACKET 1

SUPPORT 1

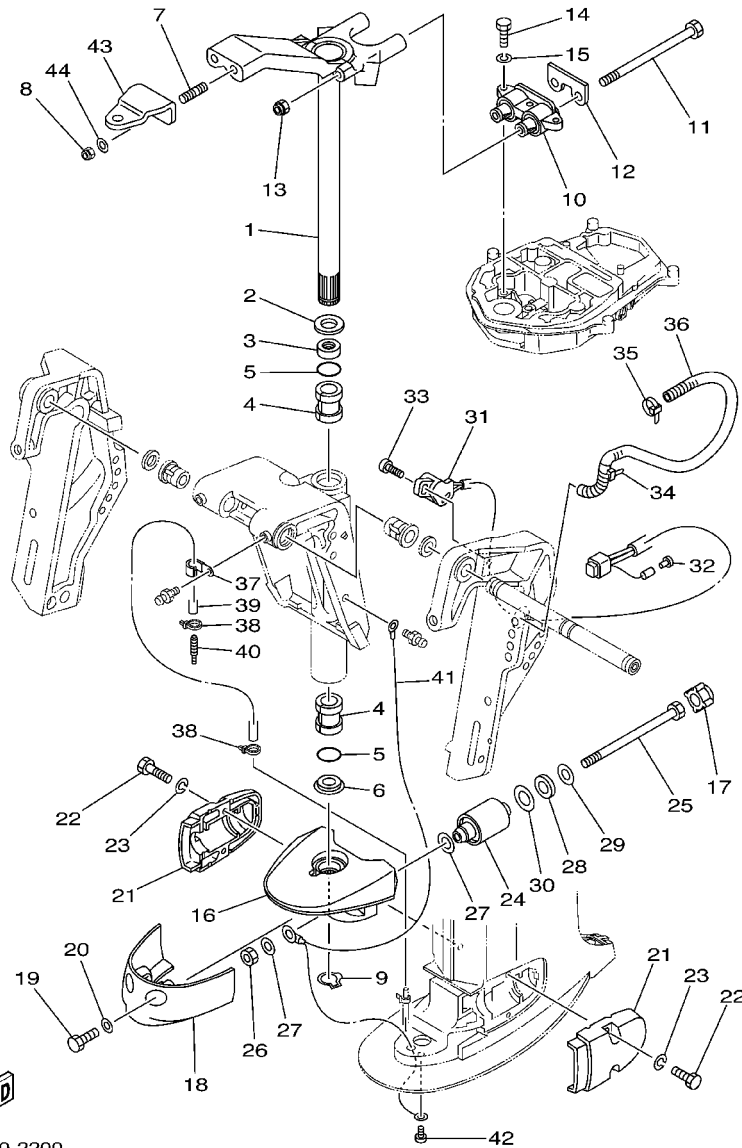


69W1010-2190

REF. NO.	PART NO. NO. PIECES	DESCRIPTION DESCRIPTION	F60A	F40C	REMARKS REMARQUES
28	91690-30012	.PIN, SPRING .AGRAFFE	1	1	
29	90502-16M02	SPRING, CONICAL RESSORT, CONIQUE	1	1	
30	65W-45251-00	ANODE ANODE	1	1	
31	90101-06020	BOLT BOULON	2	2	
32	6E5-43126-02	PIN, UPPER SHOCK MOUNT AXE, SUPERIEUR AMORTISSEUR	1	1	
33	90386-18M92	BUSH DOUILLE	1	1	
34	90386-18M35	BUSH DOUILLE	2	2	
35	93410-18M02	CIRCLIP CLIPS	1	1	
36	62Y-43818-00	PIN, LOWER SHOCK MOUNT AXE, INFERIEUR AMORTISSEUR	1	1	
37	97080-08016	BOLT BOULON	2	2	
38	90201-08M04	WASHER, PLATE RONDELLE, PLATE	2	2	
39	90387-18002	COLLAR COLLERETTE	1	1	
40	90387-18003	COLLAR COLLERETTE	1	1	
41	90101-12M65	BOLT BOULON	4	4	
42	92995-12200	WASHER RONDELLE	8	8	
43	90201-12426	WASHER, PLATE RONDELLE, PLATE	4	4	
44	95380-12600	NUT ECROU	8	8	

FIG. 17 BRACKET 2

SUPPORT 2

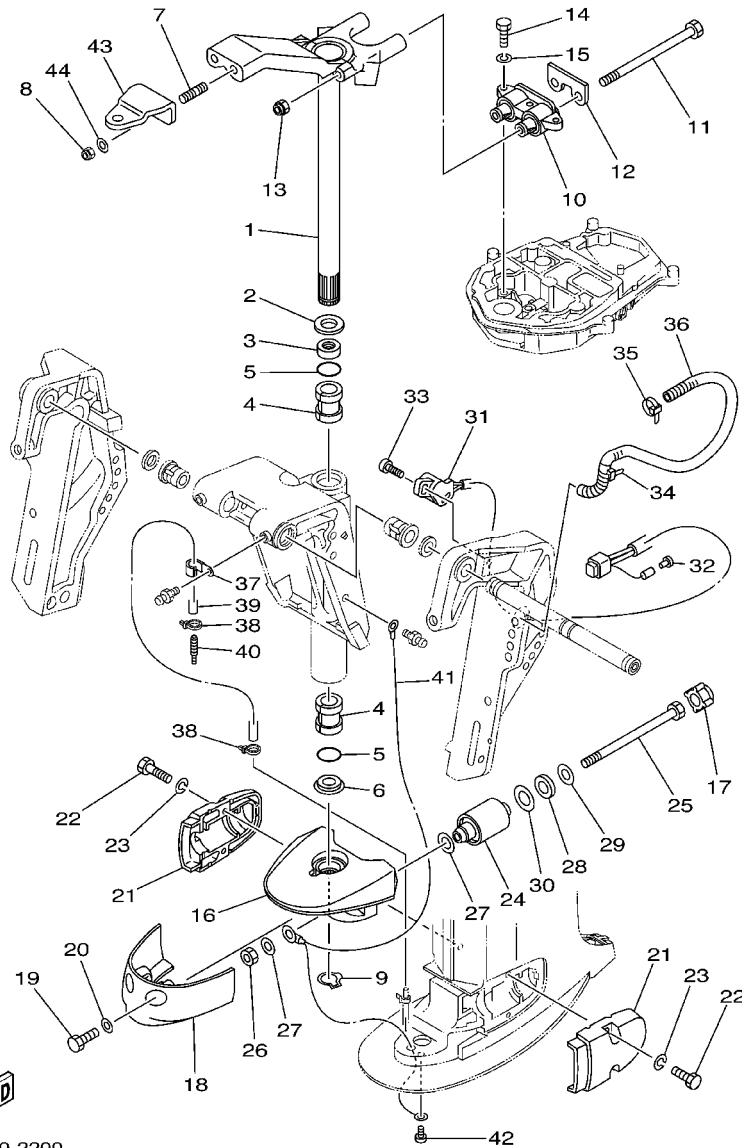


69W1010-2200

REF. NO.	PART NO. NO. PIECES	DESCRIPTION DESCRIPTION	F60A	F40C	REMARKS REMARQUES
1	69W-42510-00-4D	STEERING BRACKET ASSY DIRECTION SUPPORT (ENS.)	1	1	
2	90201-30M00	WASHER, PLATE RONDELLE, PLATE	1	1	
3	90386-30M78	BUSH DOUILLE	1	1	
4	90386-30M77	BUSH DOUILLE	2	2	
5	93210-29M94	O-RING JOINT TORIQUE	2	2	
6	90386-30M60	BUSH DOUILLE	1	1	
7	90116-10M28	BOLT, STUD GOUJON	2	2	
8	90185-10051	NUT, SELF-LOCKING ECROU, AUTO-BLOCANT	2	2	
9	93410-28M06	CIRCLIP CLIPS	1	1	
10	69W-44514-00-4D	MOUNT DAMPER, UPPER SIDE SILENT-BLOC, SUPERIEUR LATERAL	1	1	
11	90101-08M15	BOLT BOULON	2	2	
12	69W-44526-01	PLATE PLAQUE	1	1	
13	90185-08045	NUT, SELF-LOCKING ECROU, AUTO-BLOCANT	2	2	
14	97075-08030	BOLT BOULON	3	3	
15	92995-08100	WASHER RONDELLE	3	3	
16	69W-44551-00-4D	HOUSING, LOWER MOUNT RUBBER BOITIER, SILENT-BLOC INFERIEUR	1	1	
17	69W-44575-00	DAMPER, LOWER MOUNT RUBBER SILENT-BLOC, INFERIEUR	2	2	
18	67C-44553-00-4D	COVER, LOWER MOUNT COUVERCLE, SUSPENSION INFERIEUR	1	1	
19	97095-08020	BOLT BOULON	2	2	
20	92995-08600	WASHER RONDELLE	2	2	
21	67C-44552-01-4D	HOUSING, LOWER MOUNT RUBBER BOITIER, SILENT-BLOC INFERIEUR	2	2	
22	97075-08030	BOLT BOULON	4	4	
23	92995-08100	WASHER RONDELLE	4	4	
24	69W-44555-00-4D	MOUNT DAMPER, LOWER SIDE SILENT-BLOC, INFERIEUR LATERAL	2	2	
25	90109-12MA3	BOLT BOULON	2	2	
26	95380-12700	NUT ECROU	2	2	
27	90201-12M16	WASHER, PLATE RONDELLE, PLATE	4	4	

FIG. 17 BRACKET 2

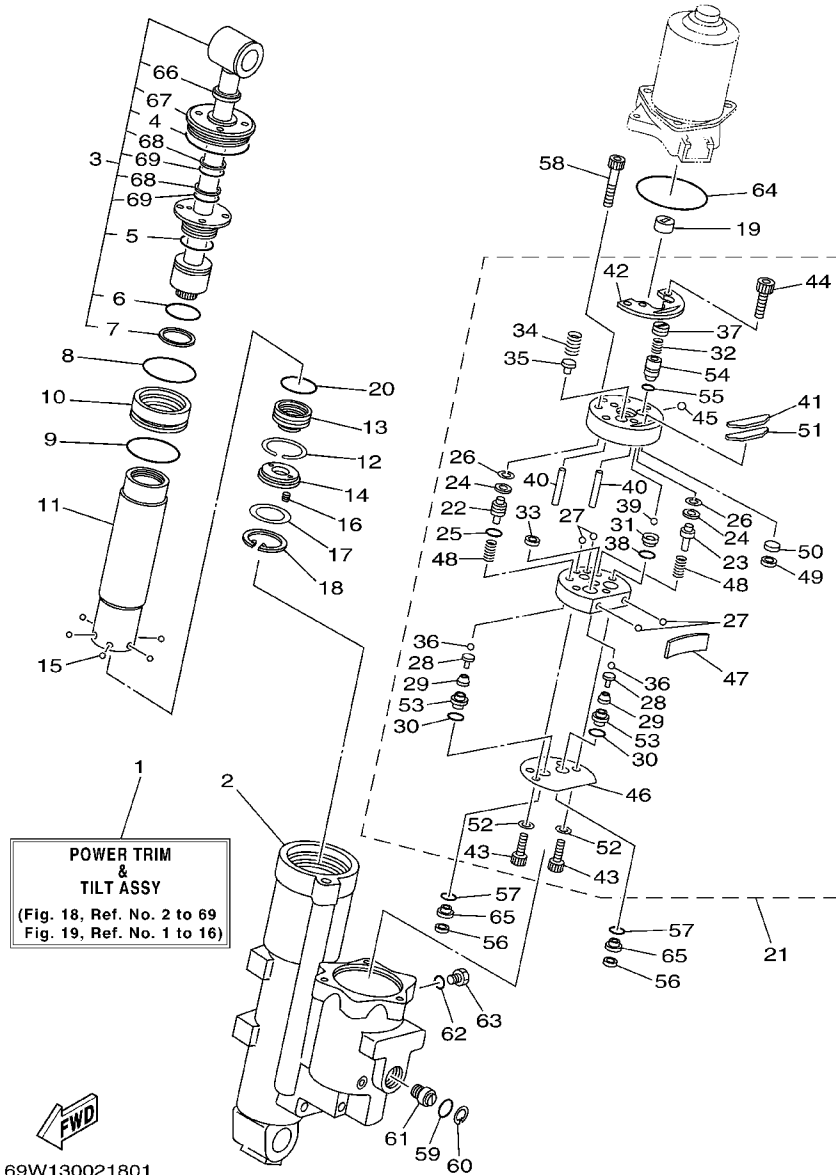
SUPPORT 2



69W1010-2200

REF. NO.	PART NO. NO. PIECES	DESCRIPTION DESCRIPTION	F60A	F40C	REMARKS REMARQUES
28	90202-21100	WASHER, PLATE RONDELLE, PLATE	2	2	
29	90201-13M19	WASHER, PLATE RONDELLE, PLATE	2	2	
30	90201-22M05	WASHER, PLATE RONDELLE, PLATE	2	2	
31	63D-83672-01	TRIM SENDER INCLINER RACCORD	1	1	
32	703-82119-00	COVER, LEAD WIRE GARNITURE, FIL	1	1	
33	97885-06016	SCREW, PAN HEAD VIS, A ENCOCHE	2	2	
34	90465-13M18	CLAMP BRIDE	1	1	
35	90465-11M10	CLAMP BRIDE	1	1	
36	90446-17M91	HOSE DURITE	1	1	
37	90465-06M86	CLAMP BRIDE	1	1	
38	90465-11M10	CLAMP BRIDE	2	2	
39	90445-07M53	HOSE (L700) DURITE (L700)	1	1	
40	6E5-83558-00	END, NIPPLE RACCORD DE NIPPLE	1	1	
41	67C-82127-10	WIRE, LEAD 2 FIL 2	1	1	
42	97885-06008	SCREW, PAN HEAD VIS, A ENCOCHE	1	1	
43	65W-48511-00	HOOK, STEERING ATTACHE, DIRECTION	1	1	
44	92995-10600	WASHER RONDELLE	2	2	

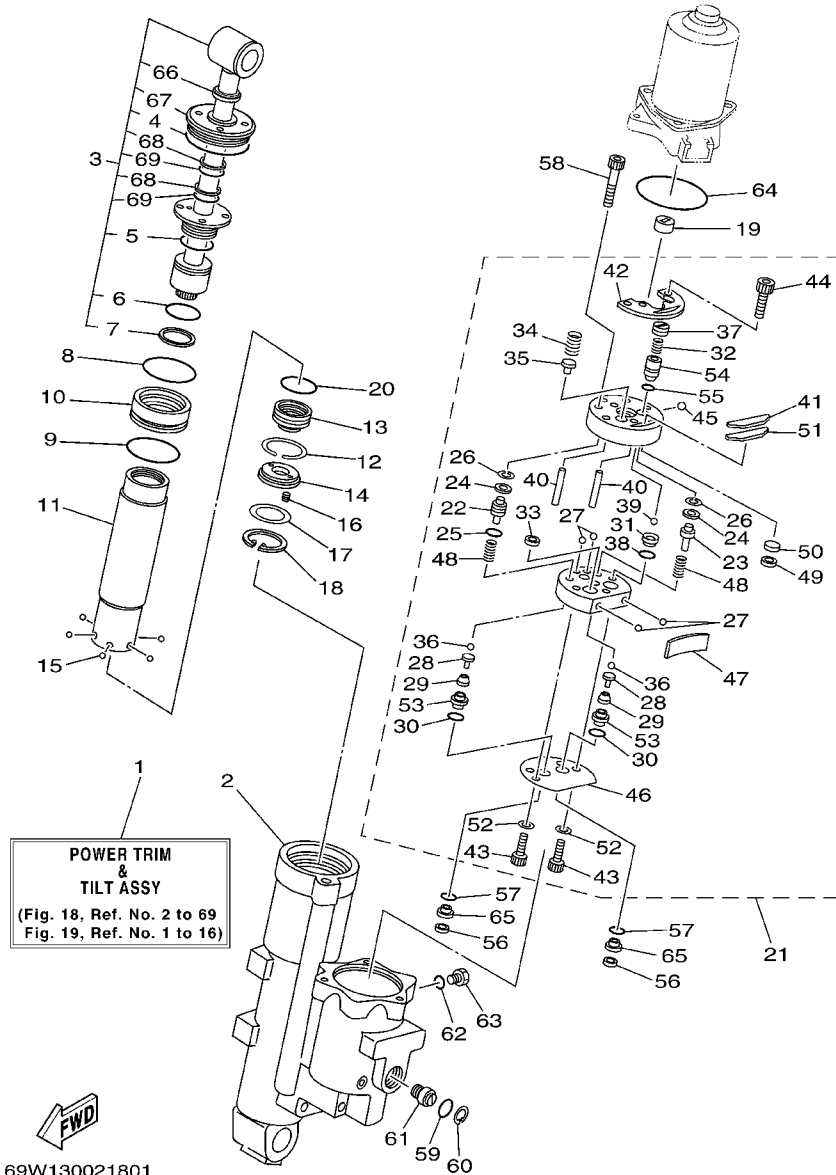
FIG. 18 POWER TRIM & TILT ASSY 1 PUISSANCE PARER ET INCLINER 1



69W130021801

REF. NO.	PART NO. NO. PIECES	DESCRIPTION DESCRIPTION	F60A	F40C	REMARKS REMARQUES
1	69W-43800-00-8D	POWER TRIM & TILT ASSY PUISSANCE PARER ET INCLINER (E	1	1	
2	69W-4380K-00	CYLINDER, TILT SUB ASSY CYLINDRE	1	1	
3	62X-43810-01	TILT PISTON SUB ASSY INCLINER PISTON AUXILIAIRE(ENS	1	1	
4	62X-43861-00	.O-RING .JOINT TORIQUE	1	1	
5	62X-43862-00	.O-RING .JOINT TORIQUE	1	1	
6	93210-29375	.O-RING .JOINT TORIQUE	1	1	
7	62X-43871-00	.RING, BACK UP .SEGMENT	1	1	
8	93210-44383	O-RING JOINT TORIQUE	1	1	
9	93210-48214	O-RING JOINT TORIQUE	1	1	
10	62X-4388A-00	PISTON, TRIM PISTON	1	1	
11	62Y-22471-00	CYLINDER, SHOCK ABSORBER CYLINDRE, AMORTISSEUR	1	1	
12	67F-43875-00	RING, SNAP RESSORT	1	1	
13	69W-4381B-00	FREE PISTON SUB ASSY PISTON AUXILIAIRE (ENS.)	1	1	
14	62X-43899-00	PLATE STOPPER PLAQUETTE	1	1	
15	93503-16003	BALL BILLES	6	6	
16	62X-4384H-00	SPRING RESSORT	2	2	
17	1UF-22434-00	PLATE, VALVE 1 PLATEAU, SOUPAPE 1	1	1	
18	62X-43875-00	RING, SNAP RESSORT	1	1	
19	6H1-43831-10	CONNECTOR, SHAFT RACCORD	1	1	
20	93210-29375	O-RING JOINT TORIQUE	1	1	
21	69W-43830-00	GEAR PUMP ASSY POMPE A PIGNON (ENS.)	1	1	
22	69J-43841-00	.PISTON, SHUTTLE .PISTON	1	1	
23	69J-4384M-00	.PISTON, SHUTTLE 2 .PISTON 2	1	1	
24	69A-4384F-00	.SEAL, MAIN VALVE .JOINT	2	2	
25	6H1-43883-00	.O-RING JOINT TORIQUE	1	1	
26	99002-03600	.CIRCLIP .CIRCLIP	2	2	
27	93505-32038	.BALL .BILLE ROULEMENT	4	4	

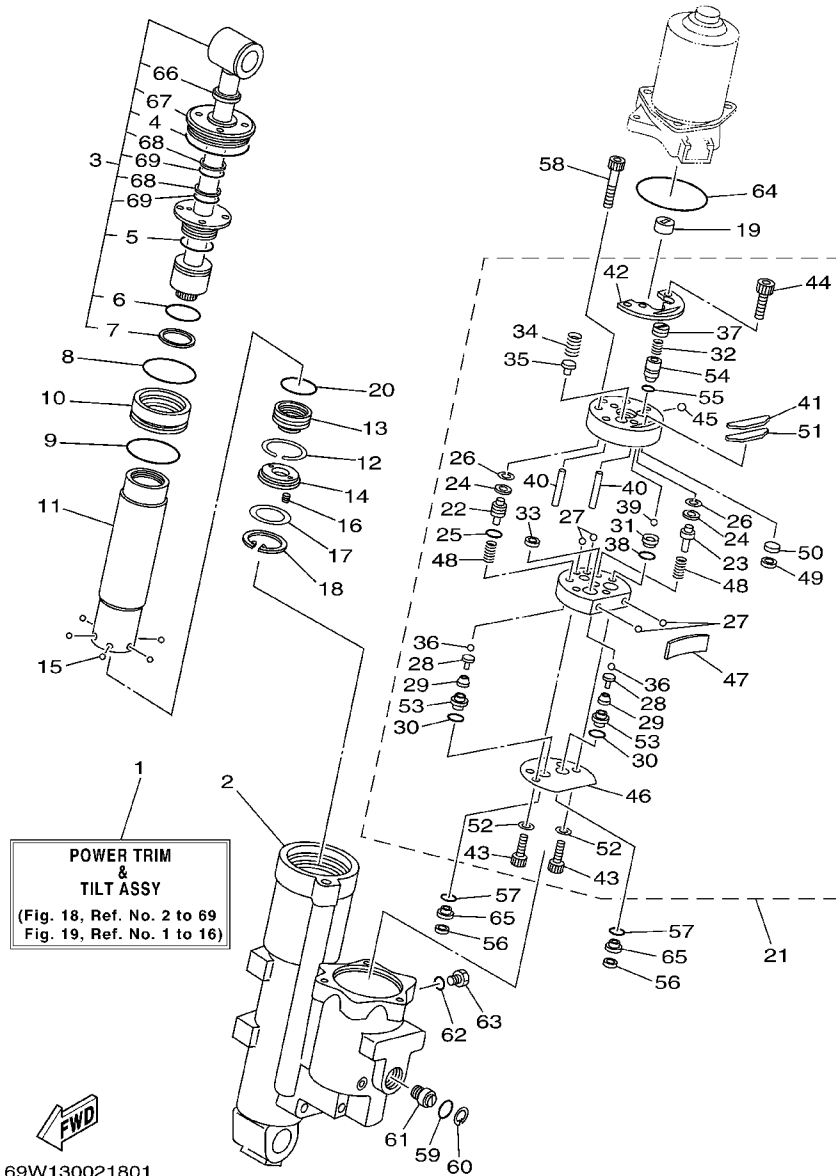
FIG. 18 POWER TRIM & TILT ASSY 1 PUISSANCE PARER ET INCLINER 1



REF. NO.	PART NO. NO. PIECES	DESCRIPTION DESCRIPTION	F60A	F40C	REMARKS REMARQUES
28	65W-4386A-00	.PIN, ABSORBER VALVE .GOUPILLE, SOUPAPE	2	2	
29	69J-43853-00	.SPRING, MAIN VALVE .RESSORT	2	2	
30	69J-4389J-00	.O-RING .JOINT TORIQUE	2	2	
31	69J-43851-00	.SEAT, RELIEF VALVE .SIEGE	1	1	
32	69J-43855-00	.SPRING, UP RELIEF .RESSORT	1	1	
33	6H1-4384F-10	.SEAL, MAIN VALVE .JOINT	1	1	
34	69W-43856-00	.SPRING, DOWN RELIEF .RESSORT	1	1	
35	6H1-43844-10	.PIN, VALVE SUPPORT .GOUPILLE	1	1	
36	93505-32038	.BALL .BILLE ROULEMENT	2	2	
37	69J-43843-00	.SCREW, VALVE LOCK .VIS	1	1	
38	93210-08391	.O-RING .JOINT TORIQUE	1	1	
39	93501-08001	.BALL .BILLE	1	1	
40	93604-26256	.PIN, DOWEL .CLAVETTE	2	2	
41	62Y-43816-00	.FILTER 1 .FILTRE 1	1	1	
42	69W-4382L-00	.CAP, RELIEF VALVE .CAPUCHON	1	1	
43	91318-05020	.BOLT .BOULON	2	2	
44	91318-05008	.BOLT .BOULON	2	2	
45	93501-08001	.BALL .BILLE	1	1	
46	69W-4384G-00	.SEAL, RELIEF VALVE .JOINT	1	1	
47	69W-43854-00	.SPRING, MANUAL RELEASE .RESSORT	1	1	
48	69J-43894-00	.SPRING, SHUTTLE RETURN .RESSORT	2	2	
49	62Y-4387J-00	.WASHER, SPECIAL 2 .RONDELLE	1	1	
50	62Y-22434-00	.PLATE, VALVE 1 .PLATEAU, SOUPAPE 1	1	1	
51	62Y-43871-00	.RING, BACK UP .SEGMENT	1	1	
52	62Y-4387G-00	.WASHER .RONDELLE	2	2	
53	69J-43893-00	.WASHER .RONDELLE	2	2	
54	69J-43844-00	.PIN, VALVE SUPPORT .GOUPILLE	1	1	

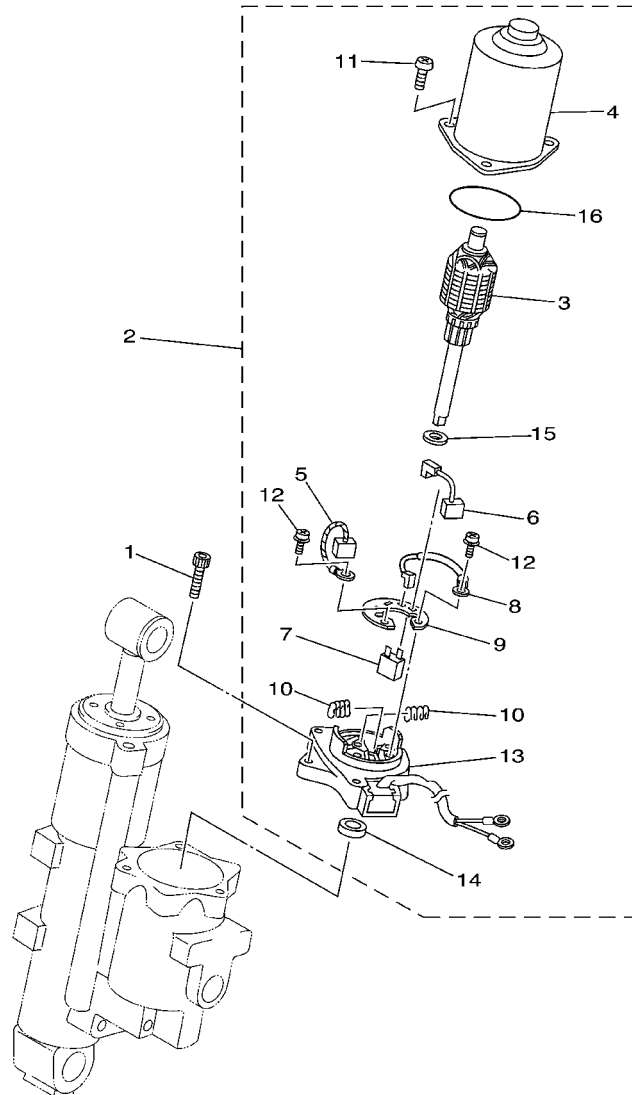


FIG. 18 POWER TRIM & TILT ASSY 1 PUISSANCE PARER ET INCLINER 1



REF. NO.	PART NO. NO. PIECES	DESCRIPTION DESCRIPTION	F60A	F40C	REMARKS REMARQUES
55	93210-064A5	.O-RING .JOINT TORIQUE	1	1	
56	6H1-43816-00	FILTER 1 FILTRE 1	2	2	
57	69J-4389J-00	O-RING JOINT TORIQUE	2	2	
58	91318-06040	BOLT BOULON	3	3	
59	93210-18397	O-RING JOINT TORIQUE	1	1	
60	6H1-43875-00	RING, SNAP RESSORT	1	1	
61	62Y-43845-00	SCREW, MANUAL RELEASE VIS	1	1	
62	93210-09165	O-RING JOINT TORIQUE	1	1	
63	6H1-43829-00	PLUG, RESERVOIR BOUCHON	1	1	
64	62X-43865-00	O-RING JOINT TORIQUE	1	1	
65	69W-43899-01	PLATE STOPPER PLAQUETTE	2	2	
66	62Y-43822-00	.SEAL, TRIM DUST .JOINT	1	1	
67	62X-43821-00	.SCREW, TRIM CYLINDER END .VIS	1	1	
68	62X-43872-00	.RING, BACK UP .RESSORT	2	2	
69	6C5-43863-00	.O-RING JOINT TORIQUE	2	2	

FIG. 19 POWER TRIM & TILT ASSY 2 PUISSANCE PARER ET INCLINER 2

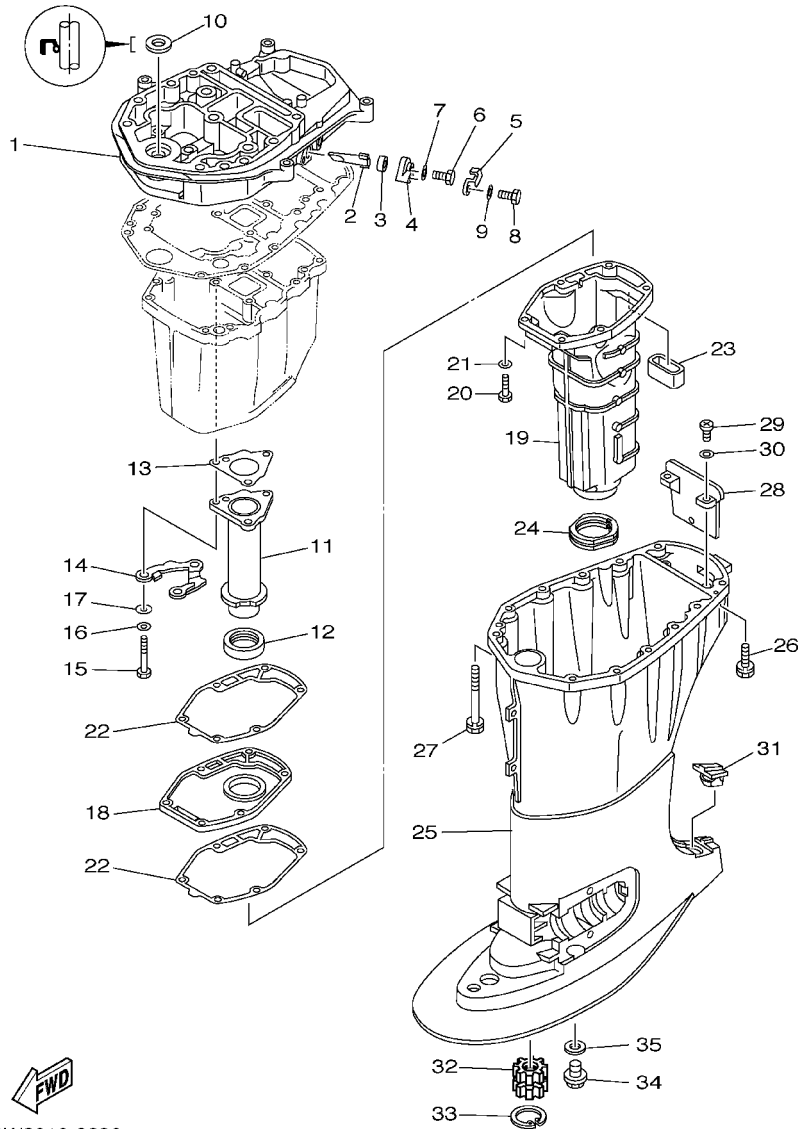


69W1010-2220

REF. NO.	PART NO. NO. PIECES	DESCRIPTION DESCRIPTION	F60A	F40C	REMARKS REMARQUES
1	62X-43888-00	BOLT, SOCKET BOULON	3	3	
2	69W-43880-00	MOTOR ASSY MOTEUR (ENS.)	1	1	
3	69W-43805-00	.ARMATURE ASSY .INDUIT (ENS.)	1	1	
4	62X-43804-01	.STATOR ASSY .STATOR (ENS.)	1	1	
5	62Y-43892-00	.BRUSH 2 .BALAI 2	1	1	
6	62Y-43891-00	.BRUSH 1 .BALAI 1	1	1	
7	69W-82181-00	.CIRCUIT BREAKER COMP. .RUPTEUR COMPLET	1	1	
8	62X-43807-00	.WIRE SUB ASSY .AUXILIAIRE CABLE (ENS.)	1	1	
9	69W-4380F-00	.PLATE, BRUSH HOLDER .PLAQUE	1	1	
10	62X-4386K-00	.SPRING, BRUSH .RESSORT, BALAI	2	2	
11	97880-05020	.SCREW, PAN HEAD .VIS, TETE TRONCONIQUE	3	3	
12	97607-04216	.SCREW, PAN HEAD WITH WASHER .VIS	2	2	
13	69W-43881-00	.FRAME, END .BATI	1	1	
14	93102-08414	.OIL SEAL .JOINT SPY	1	1	
15	90201-083J8	.WASHER, PLATE .RONDELLE, PLATE	1	1	
16	93210-52449	.O-RING .JOINT TORIQUE	1	1	

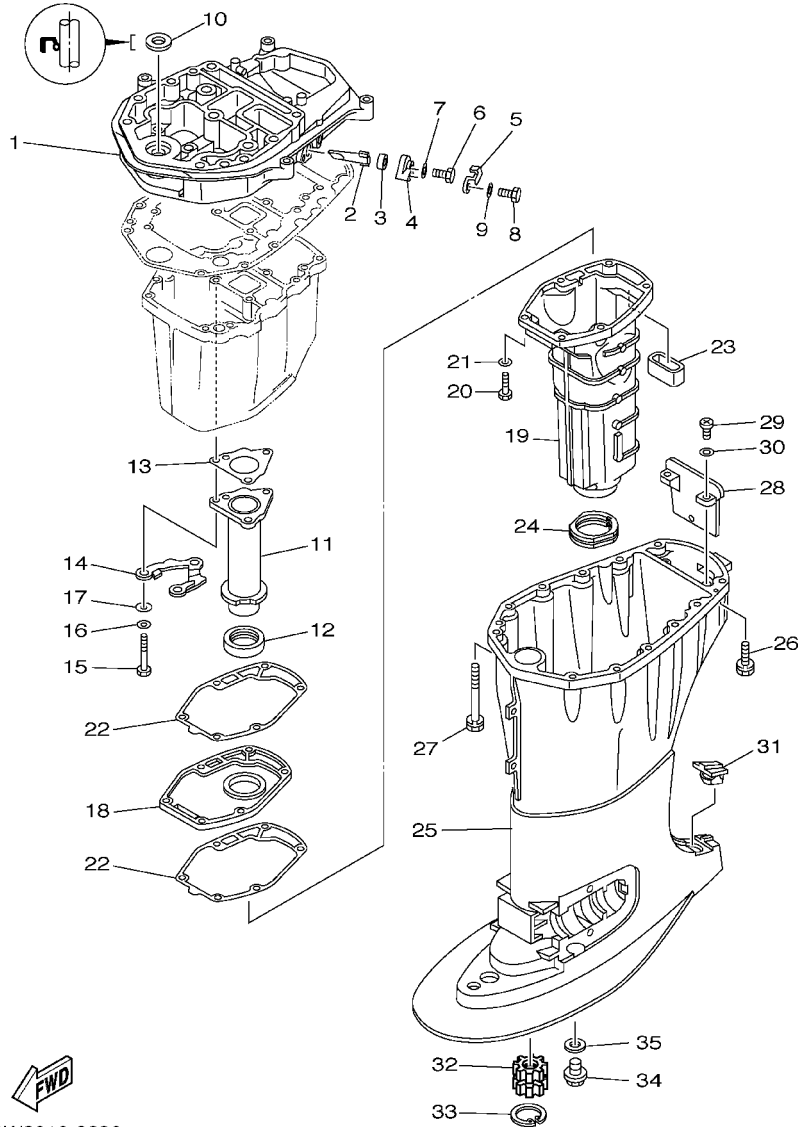
FIG. 20 UPPER CASING

FOURREAU



REF. NO.	PART NO. NO. PIECES	DESCRIPTION DESCRIPTION	F60A	F40C	REMARKS REMARQUES
1	69W-41137-01-94	GUIDE, EXHAUST COLLECTEUR D'ECHAPPEMENT	1	1	
2	62Y-11325-00	ANODE ANODE	1	1	
3	66M-11328-00	GROMMET, ANODE PASSE-FIL	1	1	
4	66M-11327-00-94	COVER, ANODE COUVERCLE	1	1	
5	66M-12535-00	PLATE PLAQUE	1	1	
6	97095-05012	BOLT BOULON	1	1	
7	92995-05600	WASHER RONDELLE	1	1	
8	97013-06020	BOLT BOULON	1	1	
9	92903-06600	WASHER, PLATE RONDELLE, PLATE	1	1	
10	93103-18011	OIL SEAL JOINT SPY	1	1	
11	69W-41131-00	MANIFOLD, EXT. 1 PIPE D'ECHAPPEMENT	1	1	
12	64J-46132-10	GASKET 1 JOINT 1	1	1	
13	64J-41133-10	GASKET, EXHAUST MANIFOLD 1 JOINT, PIPE D'ECHAPPEMENT	1	1	
14	64J-41116-00	PROTECTOR PROTECTEUR	1	1	
15	97075-06050	BOLT BOULON	3	3	
16	92995-06600	WASHER RONDELLE	3	3	
17	90201-06015	WASHER, PLATE RONDELLE, PLATE	3	3	
18	69W-45181-00-5B	PLATE PLAQUETTE	1	1	
19	69W-14711-00-5B	MUFFLER 1 POT D'ECHAPPEMENT 1	1	1	
20	97075-06025	BOLT BOULON	6	6	
21	92995-06600	WASHER RONDELLE	6	6	
22	62Y-41134-01	GASKET, EXHAUST MANIFOLD JOINT, PIPE D'ECHAPPEMENT	2	2	
23	62Y-45127-00	SEAL JOINT	1	1	
24	67C-45123-00	GASKET, MUFFLER JOINT, POT DE DETENTE	1	1	
25	67C-45111-21-4D	CASING, UPPER FOURREAU	1	1	
26	90119-08M79	BOLT, WITH WASHER BOULON, AVEC RONDELLE	4	4	
27	90119-08M82	BOLT, WITH WASHER BOULON, AVEC RONDELLE	8	8	

FWD  
69W2010-3230



69W2010-3230

FIG. 20 UPPER CASING

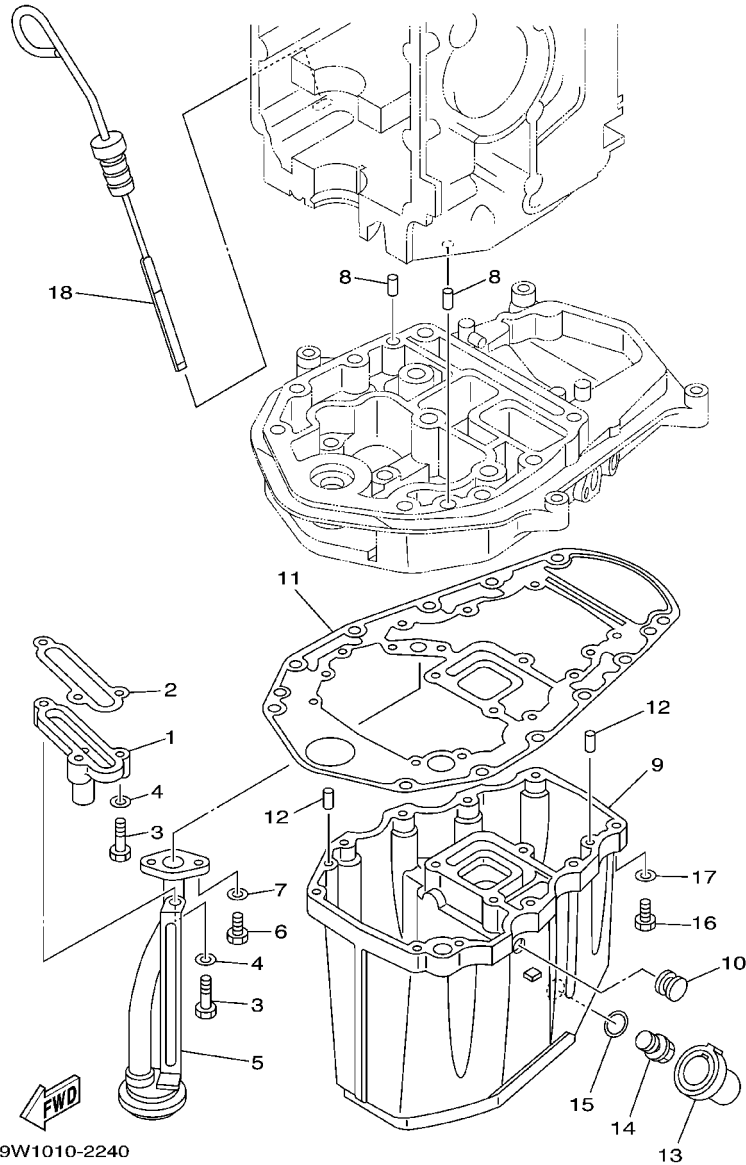
FOURREAU

REF. NO.	PART NO. NO. PIECES	DESCRIPTION DESCRIPTION	F60A	F40C	REMARKS REMARQUES
28	67C-45151-00	COVER, UPPER CASING CAPUCHON, FOURREAU	1	1	
29	97880-05016	SCREW, PAN HEAD VIS, TETE TRONCONIQUE	2	2	
30	92990-05600	WASHER, PLATE RONDELLE, PLATE	2	2	
31	6H3-45155-00	CAP CAPUCHON	1	1	
32	69W-45318-00	BUSHING, DRIVE SHAFT DQUILLE, ARBRE MOTEUR	1	1	
33	93420-36M01	CIRCLIP CIRCLIP, TYPE S	1	1	
34	90340-14M06	PLUG, STRAIGHT SCREW PLOT, FILETE DROIT	1	1	
35	90430-14M09	GASKET JOINT	1	1	
-----					
-----					
-----					
-----					
-----					
-----					
-----					
-----					
-----					
-----					
-----					
-----					
-----					

F1

FIG. 21 OIL PAN

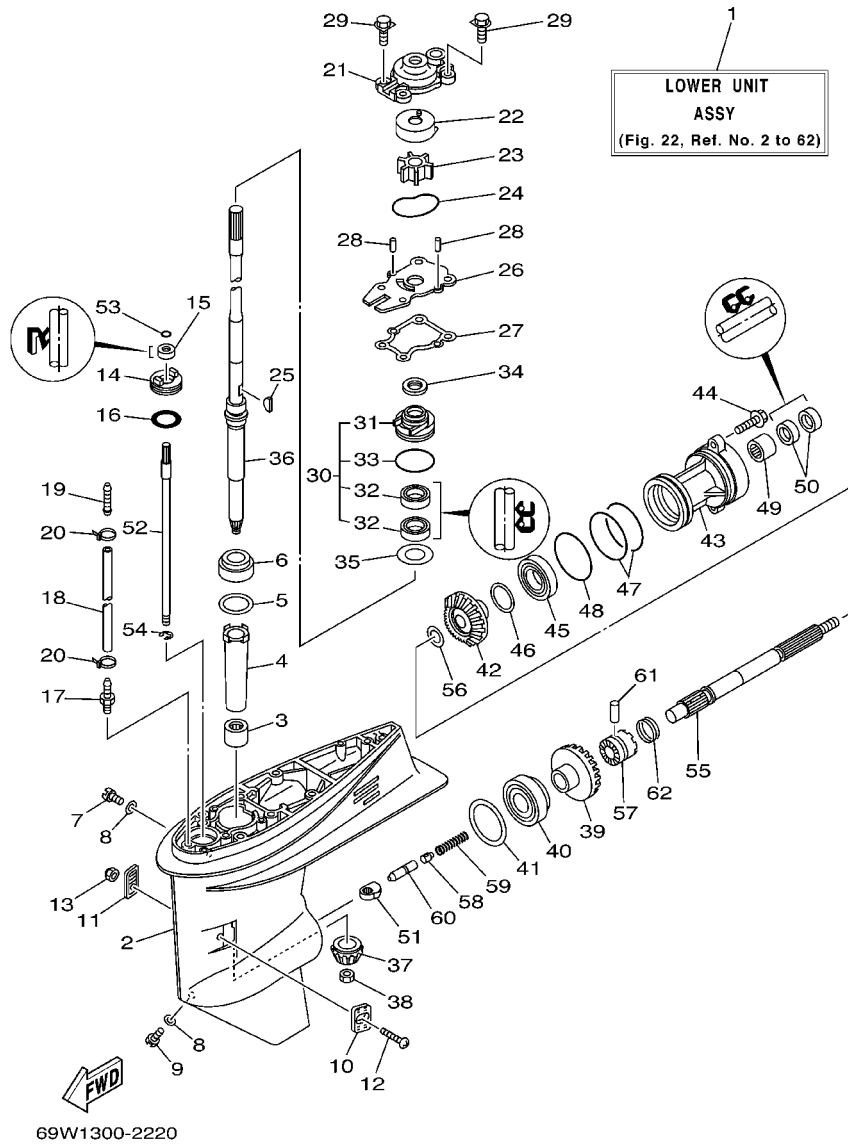
VENTILATEUR D'HUILE



REF. NO.	PART NO. NO. PIECES	DESCRIPTION DESCRIPTION	F60A	F40C	REMARKS REMARQUES
1	62Y-11575-00	RELIEF VALVE ASSY SOUPAPE DE RENTREE D'AIR	1	1	
2	62Y-13475-00	GASKET JOINT	1	1	
3	97013-06025	BOLT BOULON	3	3	
4	92903-06600	WASHER, PLATE RONDELLE, PLATE	3	3	
5	62Y-13411-00	STRAINER, OIL FILTRE, HUILE	1	1	
6	97013-06016	BOLT BOULON	2	2	
7	92903-06600	WASHER, PLATE RONDELLE, PLATE	2	2	
8	93608-12M05	PIN, DOWEL AXE	2	2	
9	64J-15311-01-5B	OIL PAN VENTILATEUR D'HUILE	1	1	
10	90480-12M25	GROMMET PASSE-FIL	1	1	
11	69W-15312-00	GASKET, OIL PAN JOINT DE VENTILATEUR D'HUILE	1	1	
12	93606-12019	PIN, DOWEL GOUPILLE	4	4	
13	67C-15316-00	DAMPER, ENGINE MOUNT 1 AMORTISSEUR DE SUPPORT	1	1	
14	90340-14M06	PLUG, STRAIGHT SCREW PLOT, FILETE DROIT	1	1	
15	90430-14M09	GASKET JOINT	1	1	
16	97075-06025	BOLT BOULON	10	10	
17	92995-06600	WASHER RONDELLE	10	10	
18	67C-15362-00	PLUG, OIL LEVEL PLOT, NIVEAU D'HUILE	1	1	

FIG. 22 LOWER CASING. DRIVE 1

BOITIER D'HELICE, TRANSMISSION 1

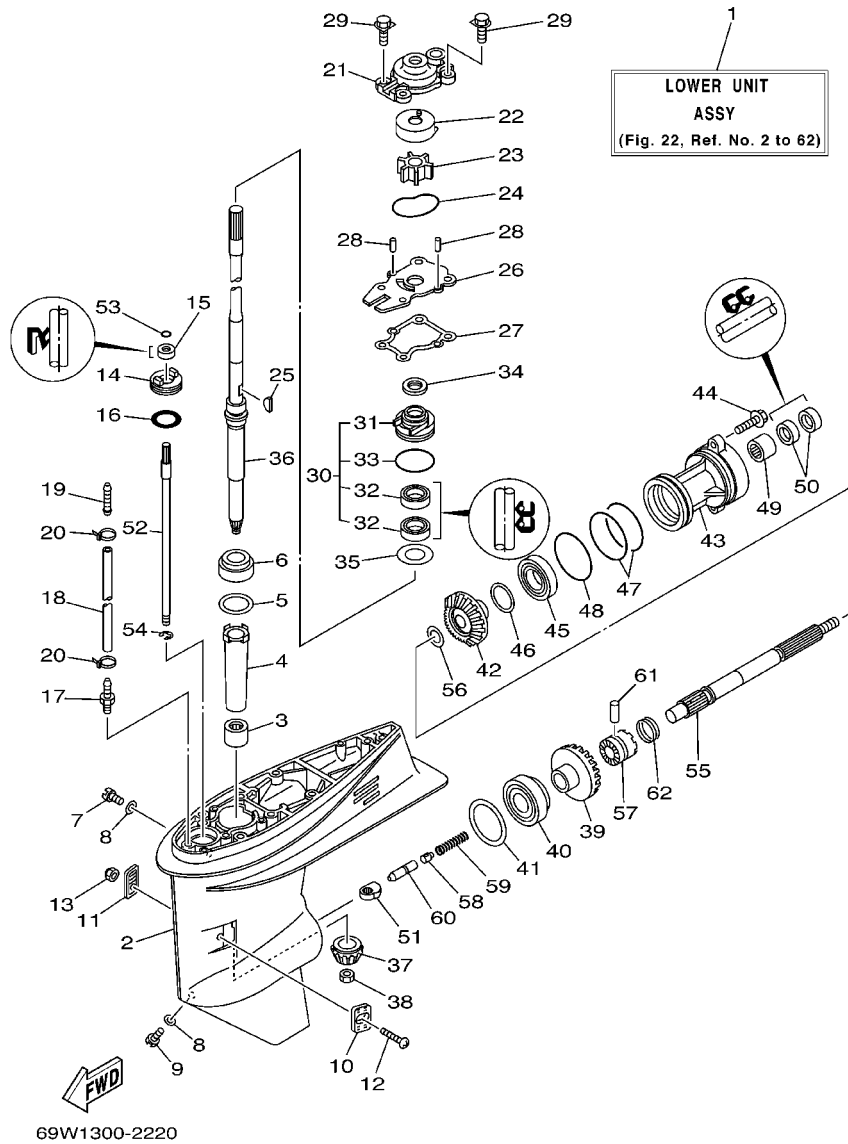


69W1300-2220

REF. NO.	PART NO. NO. PIECES	DESCRIPTION DESCRIPTION	F60A	F40C	REMARKS REMARQUES
1	69W-45300-00-4D	LOWER UNIT ASSY UNITE INFERIEURE (ENS.)	1	1	
2	69W-45301-00-4D	CASING, LOWER BEQUILLE	1	1	
3	93315-32224	BEARING ROULEMENT	1	1	
4	6H4-45536-00	SLEEVE, DRIVE SHAFT MANCHON, ARBRE MOTEUR	1	1	
5	663-45587-01-10	SHIM (T:0.10MM) CALE (T:0.10MM)	1	1	UR
663-45587-01-12	SHIM (T:0.12MM) CALE (T:0.12MM)	1	1	UR	
663-45587-01-15	SHIM (T:0.15MM) CALE (T:0.15MM)	1	1	UR	
663-45587-01-18	SHIM (T:0.18MM) CALE (T:0.18MM)	1	1	UR	
663-45587-01-30	SHIM (T:0.30MM) CALE (T:0.30MM)	1	1	UR	
663-45587-01-40	SHIM (T:0.40MM) CALE (T:0.40MM)	1	1	UR	
663-45587-01-50	SHIM (T:0.50MM) CALE (T:0.50MM)	1	1	UR	
6	93332-00001	BEARING ROULEMENT	1	1	
7	90340-08002	PLUG, STRAIGHT SCREW PLOT, FILETE DROIT	1	1	
8	90430-08020	GASKET JOINT	2	2	
9	688-45341-10	PLUG, DRAIN BOUCHON DE VIDANGE	1	1	
10	63D-45214-00	COVER, WATER INLET GRILLE, ENTREE D'EAU	1	1	
11	63D-45215-00	COVER, WATER INLET GRILLE, ENTREE D'EAU	1	1	
12	90142-05M06	SCREW, COUNTERSUNK VIS, TETE NOYEE	1	1	
13	95380-05600	NUT ECROU	1	1	
14	63D-45321-00	PLATE PLAQUETTE	1	1	
15	93106-09014	OIL SEAL JOINT SPY	1	1	
16	93210-33MG4	O-RING JOINT TORIQUE	1	1	
17	6E5-45378-00	NIPPLE, HOSE RACCORD, TUYAU	1	1	
18	90445-07ME8	HOSE (L80) DURITE (L80)	1	1	
19	6E5-83558-10	END, NIPPLE RACCORD DE NIPPLE	1	1	
20	90465-11M10	CLAMP BRIDE	2	2	
21	63D-44311-00	HOUSING, WATER PUMP CORPS, POMPE A EAU	1	1	

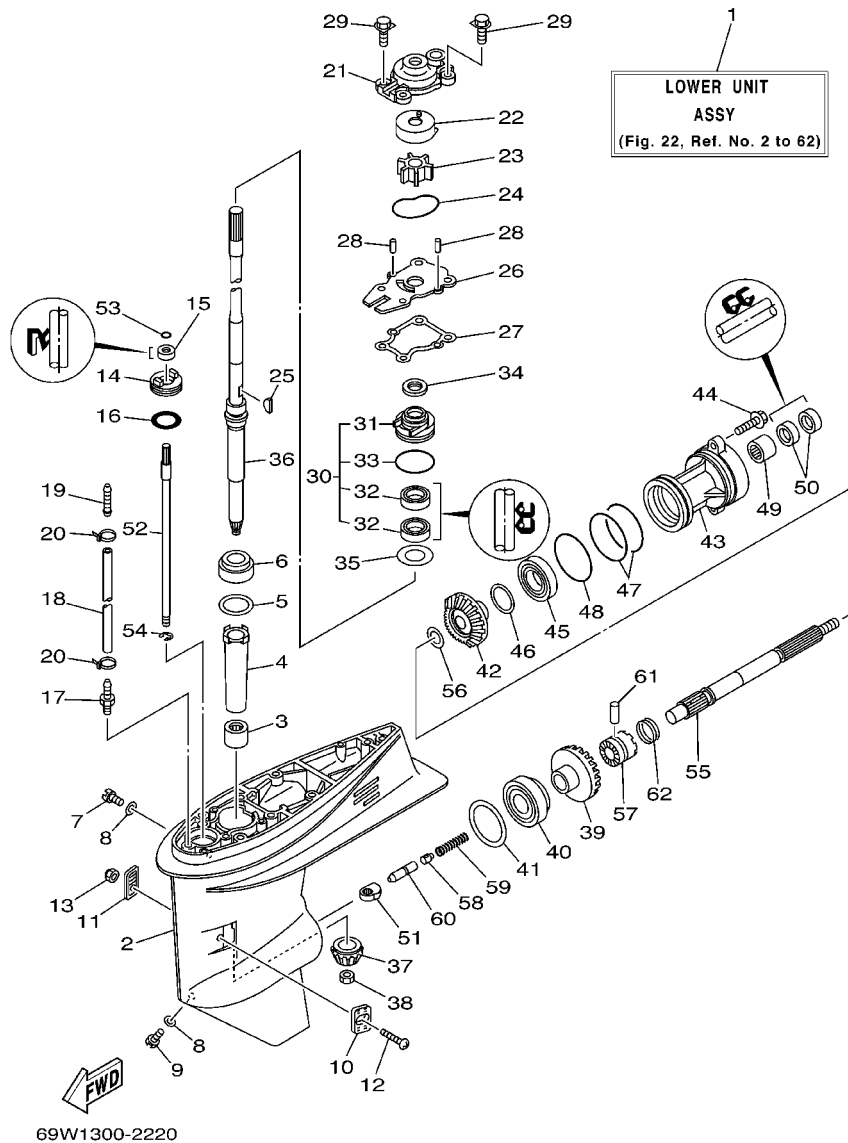
FIG. 22 LOWER CASING. DRIVE 1

BOITIER D'HELICE, TRANSMISSION 1



69W1300-2220

REF. NO.	PART NO. NO. PIECES	DESCRIPTION DESCRIPTION	F60A	F40C	REMARKS REMARQUES
22	63D-44322-00	INSERT, CARTRIDGE CUVETTE	1	1	
23	6H3-44352-00	IMPELLER TURBINE	1	1	
24	93210-59MG7	O-RING JOINT TORIQUE	1	1	
25	90280-03024	KEY, WOODRUFF CLAVETTE, DEMI-LUNE	1	1	
26	63D-44323-00	OUTER PLATE, CARTRIDGE PLAQUE EXTERIEURE	1	1	
27	63D-44316-00	GASKET, WATER PUMP JOINT, POMPE A EAU	1	1	
28	93604-08062	PIN, DOWEL CLAVETTE	2	2	
29	90119-08M15	BOLT, WITH WASHER BOULON, AVEC RONDELLE	4	4	
30	63D-W4434-00	WATER PUMP HOUSING ASSY CORPS ENS., POMPE A EAU	1	1	
31	63D-44341-00	HOUSING, WATER PUMP CORPS, POMPE A EAU	1	1	
32	93101-25M57	OIL SEAL JOINT SPY	2	2	
33	93210-48MG8	O-RING JOINT TORIQUE	1	1	
34	63D-45344-00	COVER, OIL SEAL FLASQUE, JOINT D'HUILE	1	1	
35	90201-27M00	WASHER, PLATE RONDELLE, PLATE	1	1	
36	69W-45501-00	DRIVE SHAFT COMP. ARBRE MOTEUR COMP.	1	1	
37	69W-45551-00	PINION PIGNON D'ATTAQUE	1	1	
38	90170-12138	NUT ECROU	1	1	
39	69W-45560-00	GEAR PIGNON	1	1	
40	93332-00092	BEARING ROULEMENT	1	1	
41	663-45567-01-10	SHIM (T:0.10MM) CALE (T:0.10MM)	1	1	UR
41	663-45567-01-12	SHIM (T:0.12MM) CALE (T:0.12MM)	1	1	UR
41	663-45567-01-15	SHIM (T:0.15MM) CALE (T:0.15MM)	1	1	UR
41	663-45567-01-18	SHIM (T:0.18MM) CALE (T:0.18MM)	1	1	UR
41	663-45567-01-30	SHIM (T:0.30MM) CALE (T:0.30MM)	1	1	UR
41	663-45567-01-40	SHIM (T:0.40MM) CALE (T:0.40MM)	1	1	UR
41	663-45567-01-50	SHIM (T:0.50MM) CALE (T:0.50MM)	1	1	UR
42	62Y-45571-00	GEAR PIGNON	1	1	



69W1300-2220

FIG. 22 LOWER CASING. DRIVE 1

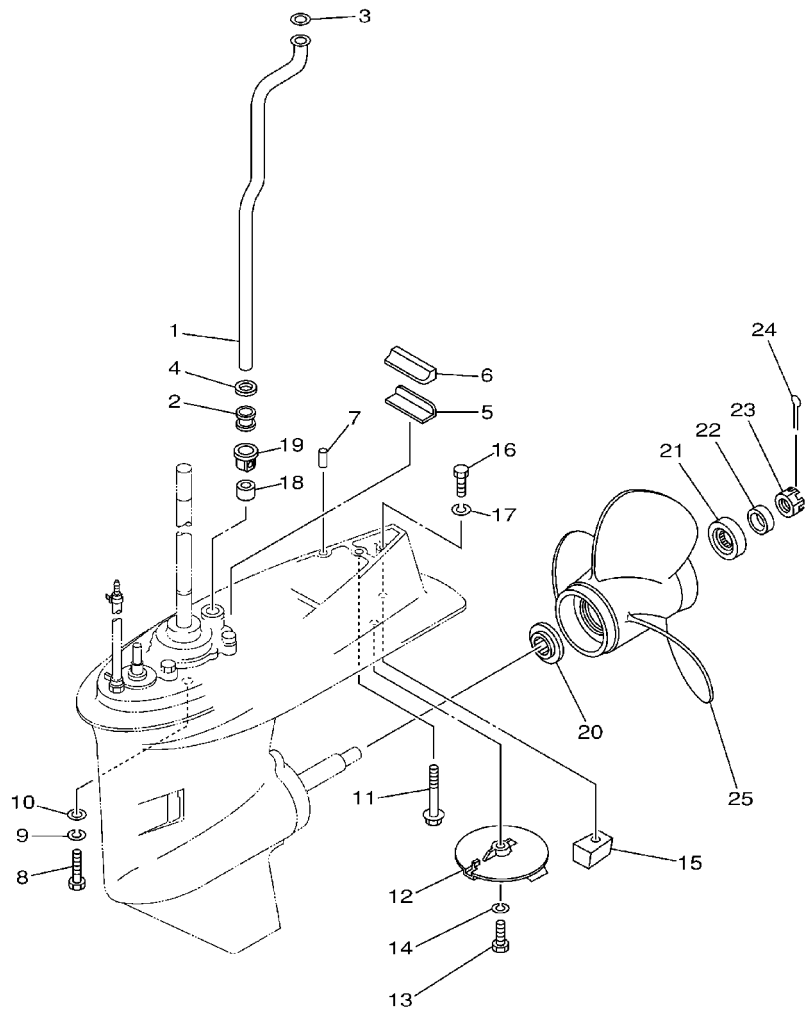
BOITIER D'HELICE, TRANSMISSION 1

REF. NO.	PART NO. NO. PIECES	DESCRIPTION DESCRIPTION	F60A	F40C	REMARKS REMARQUES
43	63D-45361-02-4D	CAP, LOWER CASING COUVERCLE, BOITIER D'HELICE	1	1	
44	90105-08M61	BOLT, FLANGE BOULON	2	2	
45	93306-001U1	BEARING ROULEMENT	1	1	
46	63D-45577-00-10	SHIM (T:0.10MM) CALE (T:0.10MM)	1	1	UR
	63D-45577-00-12	SHIM (T:0.12MM) CALE (T:0.12MM)	1	1	UR
	63D-45577-00-15	SHIM (T:0.15MM) CALE (T:0.15MM)	1	1	UR
	63D-45577-00-18	SHIM (T:0.18MM) CALE (T:0.18MM)	1	1	UR
	63D-45577-00-30	SHIM (T:0.30MM) CALE (T:0.30MM)	1	1	UR
	63D-45577-00-40	SHIM (T:0.40MM) CALE (T:0.40MM)	1	1	UR
	63D-45577-00-50	SHIM (T:0.50MM) CALE (T:0.50MM)	1	1	UR
47	93210-74MG5	O-RING JOINT TORIQUE	2	2	
48	93210-69MG6	O-RING JOINT TORIQUE	1	1	
49	93317-22204	BEARING PIECE	1	1	
50	93101-22M00	OIL SEAL JOINT SPY	2	2	
51	62Y-44151-00	CAM, SHIFT CAME, INVERSION	1	1	
52	63D-44144-00	ROD, SHIFT TIGE D'EMBAYAGE	1	1	
53	93210-07003	O-RING JOINT TORIQUE	1	1	
54	99001-08600	CIRCLIP CIRCLIP	1	1	
55	63D-45611-00	SHAFT, PROPELLER ARBRE, HELICE	1	1	
56	90201-22008	WASHER, PLATE RONDELLE, PLATE	1	1	
57	62Y-45631-00	CLUTCH, DOG CRABOT	1	1	
58	663-45634-00	SLIDE, SHIFT CONTRE-POUSSOIR	1	1	
59	90501-18001	SPRING, COMPRESSION RESSORT, COMPRESSION	1	1	
60	63D-45635-00	PLUNGER, SHIFT POUSSOIR D'EMBAYAGE	1	1	
61	90250-06023	PIN, STRAIGHT GOUILLE, DROITE	1	1	
62	67C-45633-00	RING, CROSS PIN JONC, GOUILLE CRABOT	1	1	



FIG. 23 LOWER CASING. DRIVE 2

BOITIER D'HELICE, TRANSMISSION 2

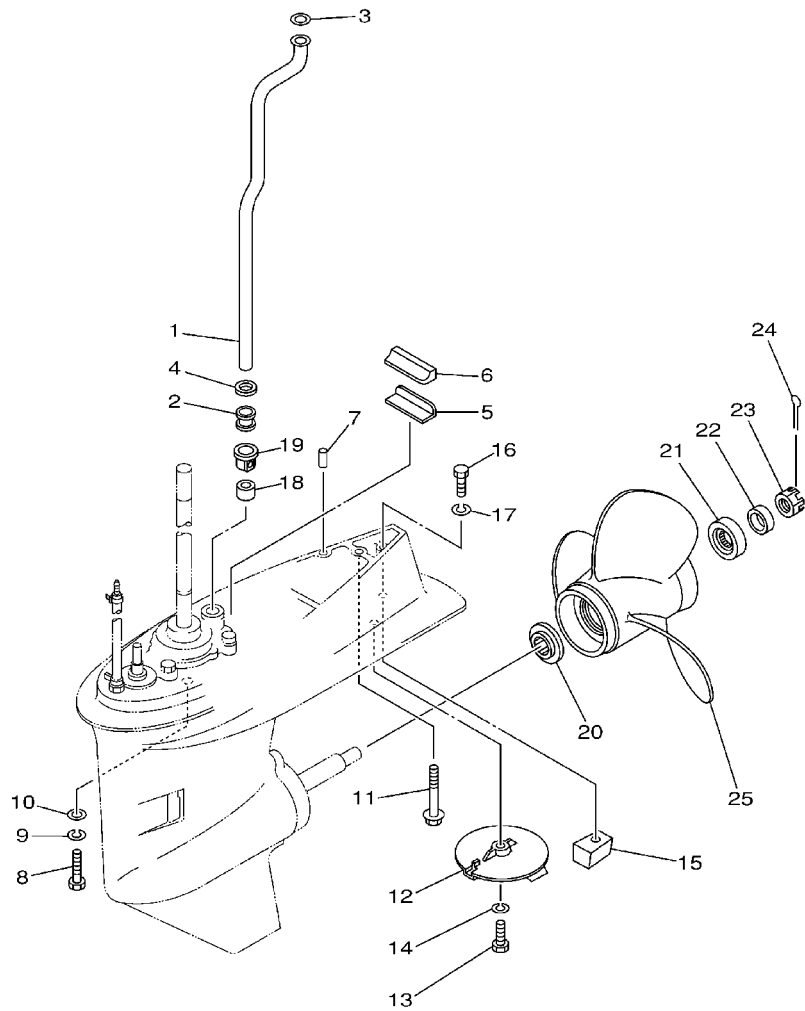


  
62Y0100-1270

REF. NO.	PART NO. NO. PIECES	DESCRIPTION DESCRIPTION	F60A	F40C	REMARKS REMARQUES
1	62Y-44361-00	TUBE, WATER TUBE D'EAU	1	1	
2	663-44367-00	DAMPER, WATER SEAL JOINT TUBE D'EAU	1	1	
3	90202-12060	WASHER, PLATE RONDELLE, PLATE	1	1	
4	90430-12072	GASKET JOINT	1	1	
5	663-45376-00-94	GUIDE, SEAL DAMPER BUTEE, JOINT CAOUTCHOUC	1	1	
6	63D-45375-00	DAMPER, SEAL BOURRELET, CAOUTCHOUC	1	1	
7	93606-12019	PIN, DOWEL GOUVILLE	2	2	
8	97075-10040	BOLT BOULON	4	4	
9	92995-10100	WASHER RONDELLE	4	4	
10	92995-10600	WASHER RONDELLE	4	4	
11	90119-08M84	BOLT, WITH WASHER BOULON, AVEC RONDELLE	1	1	
12	67C-45371-00	TAB-TRIM ANODE DERIVE	1	1	
13	97095-08025	BOLT BOULON	1	1	
14	92995-08100	WASHER RONDELLE	1	1	
15	67C-45251-00	ANODE ANODE	1	1	
16	97095-08035	BOLT BOULON	1	1	
17	92995-08100	WASHER RONDELLE	1	1	
18	663-44366-00	DAMPER, WATER SEAL JOINT, TUBE D'EAU	1	1	
19	63D-44312-00	COVER, WATER PUMP HOUSING COUVERCLE	1	1	
20	663-45987-02	SPACER ENTRETOISE	1	1	
21	66T-45997-00	SPACER ENTRETOISE	1	1	
22	90389-22M01	BUSH DOUILLE	1	1	
23	90171-16011	NUT, CASTLE ECROU, CRENELE	1	1	
24	91490-30025	PIN, COTTER GOUVILLE	1	1	
25	69W-45943-00-EL	PROPELLER (3X11"X15"-G) HELICE (3X11"X15"-G)	1	1	UR
	69W-45947-00-EL	PROPELLER (3X11-5/8"X11"-G) HELICE (3X11-5/8"X11"-G)	1	1	UR
	663-45949-01-EL	PROPELLER (3X10-3/4"X16"-G) HELICE (3X10-3/4"X16"-G)	1	1	UR

FIG. 23 LOWER CASING. DRIVE 2

BOITIER D'HELICE, TRANSMISSION 2

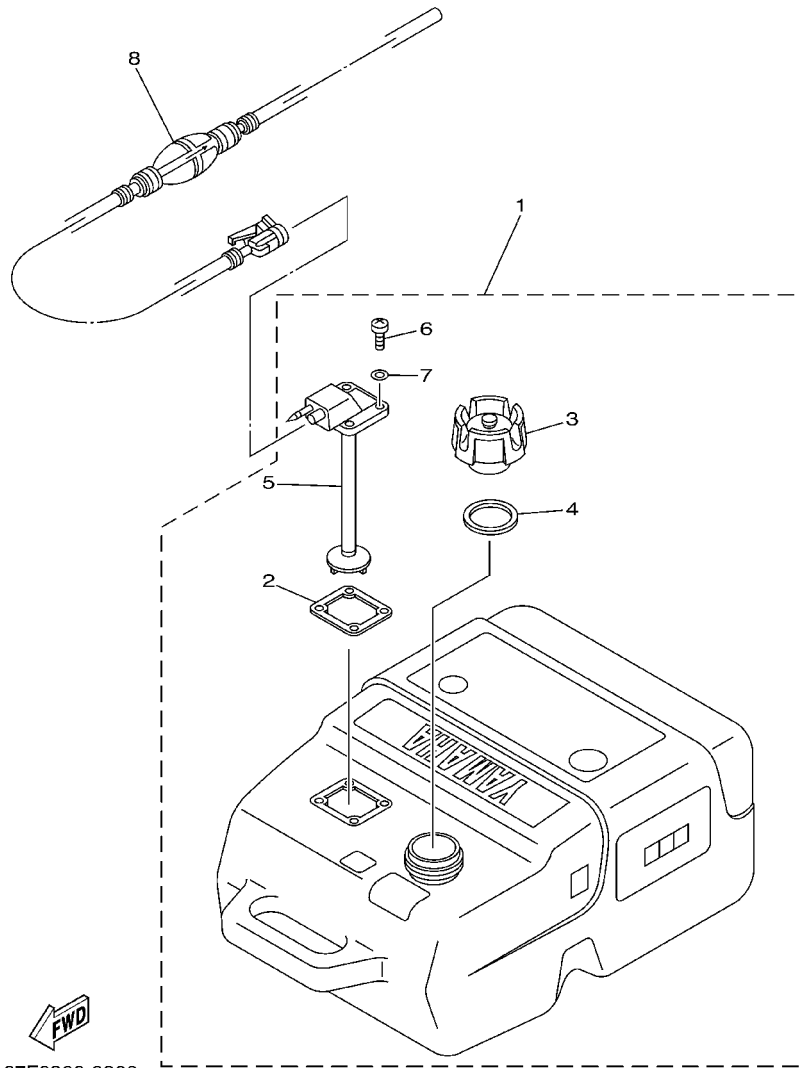


**FWD**  
62Y0100-1270

REF. NO.	PART NO. NO. PIECES	DESCRIPTION DESCRIPTION	F60A	F40C	REMARKS REMARQUES
25	663-45954-01-EL	PROPELLER (3X11-3/4"X10"-G) HELICE (3X11-3/4"X10"-G)	1	1	UR
	663-45956-01-EL	PROPELLER (3X12-1/4"X9"-G) HELICE (3X12-1/4"X9"-G)	1	1	UR
	6H5-45943-00-EL	PROPELLER (3X10"X15"-G) HELICE (3X10"X15"-G)	1	1	UR WITH LIP CUP
	6H5-45945-00-EL	PROPELLER (3X10-3/8"X13"-G) HELICE (3X10-3/8"X13"-G)	1	1	UR WITH LIP CUP
	6H5-45952-00-EL	PROPELLER (3X10-5/8"X12"-G) HELICE (3X10-5/8"X12"-G)	1	1	UR WITH LIP CUP
-----					
<b>STAINLESS STEEL PROPELLER ACIER INOXYDABLE HELICE</b>					
	663-45930-00-98	PROPELLER (3X10-1/4"X14"-G) HELICE (3X10-1/4"X14"-G)	1	1	UR
	663-45974-02-98	PROPELLER (3X10-5/8"X13"-G) HELICE (3X10-5/8"X13"-G)	1	1	UR
	663-45976-00-98	PROPELLER (3X10-1/4"X15"-G) HELICE (3X10-1/4"X15"-G)	1	1	UR
	663-45978-00-98	PROPELLER (3X10-1/4"X16"-G) HELICE (3X10-1/4"X16"-G)	1	1	UR
	663-45970-60-98	PROPELLER (3X11-3/4"X12"-G) HELICE (3X11-3/4"X12"-G)	1	1	UR
	663-45972-60-98	PROPELLER (3X12"X11"-G) HELICE (3X12"X11"-G)	1	1	UR
	663-45974-60-98	PROPELLER (3X11-1/2"X13"-G) HELICE (3X11-1/2"X13"-G)	1	1	UR
-----					
-----					
-----					
-----					
-----					

FIG. 24 FUEL TANK

RESERVOIR A CARBURANT

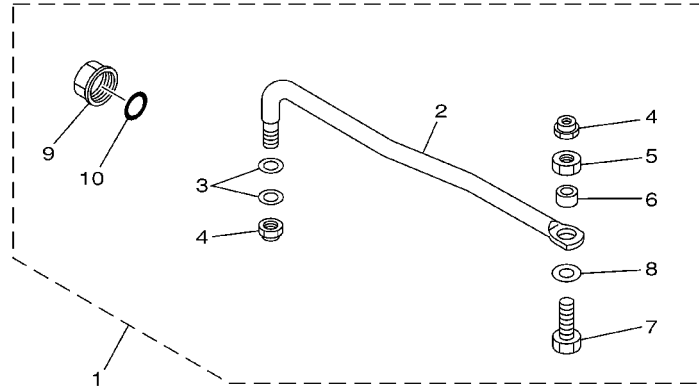


67F0300-9300

REF. NO.	PART NO. NO. PIECES	DESCRIPTION DESCRIPTION	F60A	F40C	REMARKS REMARQUES
1	6YK-24201-01	FUEL TANK ASSY RESERVOIR A ESSENCE (ENS.)	1	1	AP PLASTIC, 25L
2	6YL-24268-01	.GASKET, FUEL METER .JOINT, JAUGE A CARBURANT	1	1	
3	6YK-24610-00	.CAP ASSY .BOUCHON	1	1	WITH INDICATOR
4	6YL-24641-00	.GASKET, CAP 1 .JOINT 1, BOUCHON	1	1	
5	6YK-24260-01	.FUEL METER ASSY .INDICATEUR DE CARBURANT	1	1	
6	90157-05M16	.SCREW, PAN HEAD .VIS, TETE TRONCONIQUE	4	4	
7	6YL-24329-00	.SEAL .JOINT	4	4	
8	6YL-24306-52	FUEL PIPE COMP. 1 DURITE A ESSENCE 1	1	1	AP

FIG. 25 STEERING GUIDE

FIXATION DE DIRECTION

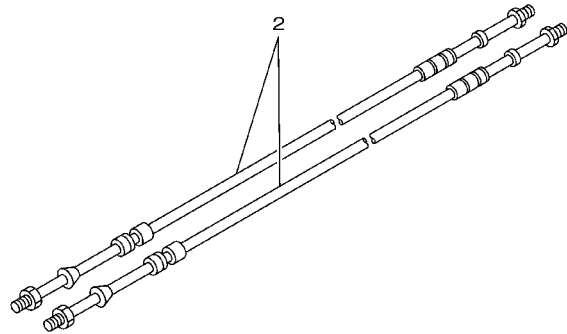
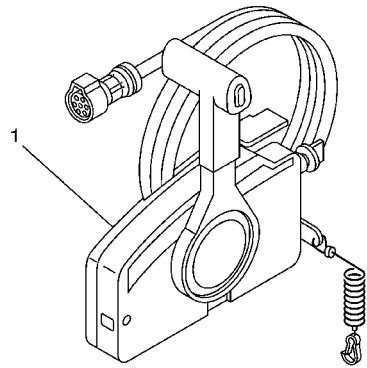


REF. NO.	PART NO. NO. PIECES	DESCRIPTION DESCRIPTION	F60A	F40C	REMARKS REMARQUES
1	65W-61350-00	STEERING GUIDE ATTACHMENT KIT FIXATIONS DE DIRECTION	1	1	AP
2	65W-61351-00	.ROD, STEERING LINK .REVOI DE DIRECTION	1	1	
3	90201-10M20	.WASHER, PLATE .RONDELLE, PLATE	2	2	
4	90185-09M01	.NUT, SELF-LOCKING .ECROU, AUTO-BLOCANT	2	2	
5	90170-09M03	.NUT .ECROU	1	1	
6	90387-10M42	.COLLAR .COLLERETTE	1	1	
7	90101-09M01	.BOLT .BOULON	1	1	
8	90201-10M63	.WASHER, PLATE .RONDELLE, PLATE	1	1	
9	6E5-43145-01	.CAP, CLAMP BRACKET .CAPUCHON, PRESSE	1	1	
10	93210-16275	.O-RING .JOINT TORIQUE	1	1	

65W0010-8210

**FIG. 26 REMOTE CONTROL BOX**

**BOITIER DE COMMANDE A DISTANCE**

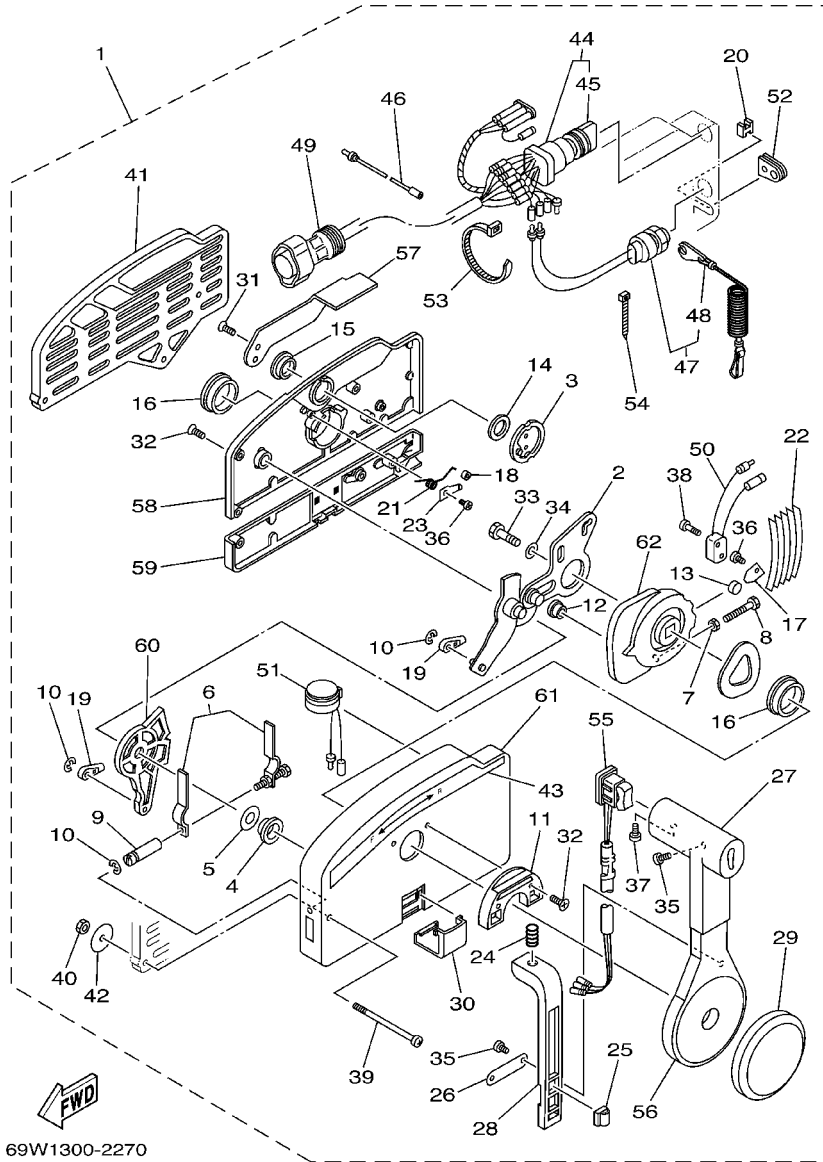


REF. NO.	PART NO. NO. PIECES	DESCRIPTION DESCRIPTION	F60A	F40C				REMARKS REMARQUES
1	703-48207-17	REMOTE CONTROL ASSY BOITIER DE COMMANDE A DISTANCE	1	1				AP WITH PT/T SW.
2	701-48310-90	CABLE, REMOTE CONTROL L=11F CABLE, COMMANDE A DISTANCE:11F	2	2				UR
	701-48320-00	CABLE, REMOTE CONTROL L=12F CABLE, COMMANDE A DISTANCE:12F	2	2				UR
	701-48320-20	CABLE, REMOTE CONTROL L=13F CABLE, COMMANDE A DISTANCE:13F	2	2				UR
	701-48320-50	CABLE, REMOTE CONTROL L=15F CABLE, COMMANDE A DISTANCE:15F	2	2				UR
-----								
-----								
-----								
-----								
-----								
-----								
-----								

  
67M0100-8280

FIG. 27 REMOTE CONTROL ASSY

BOITIER DE COMMANDE A DISTANCE

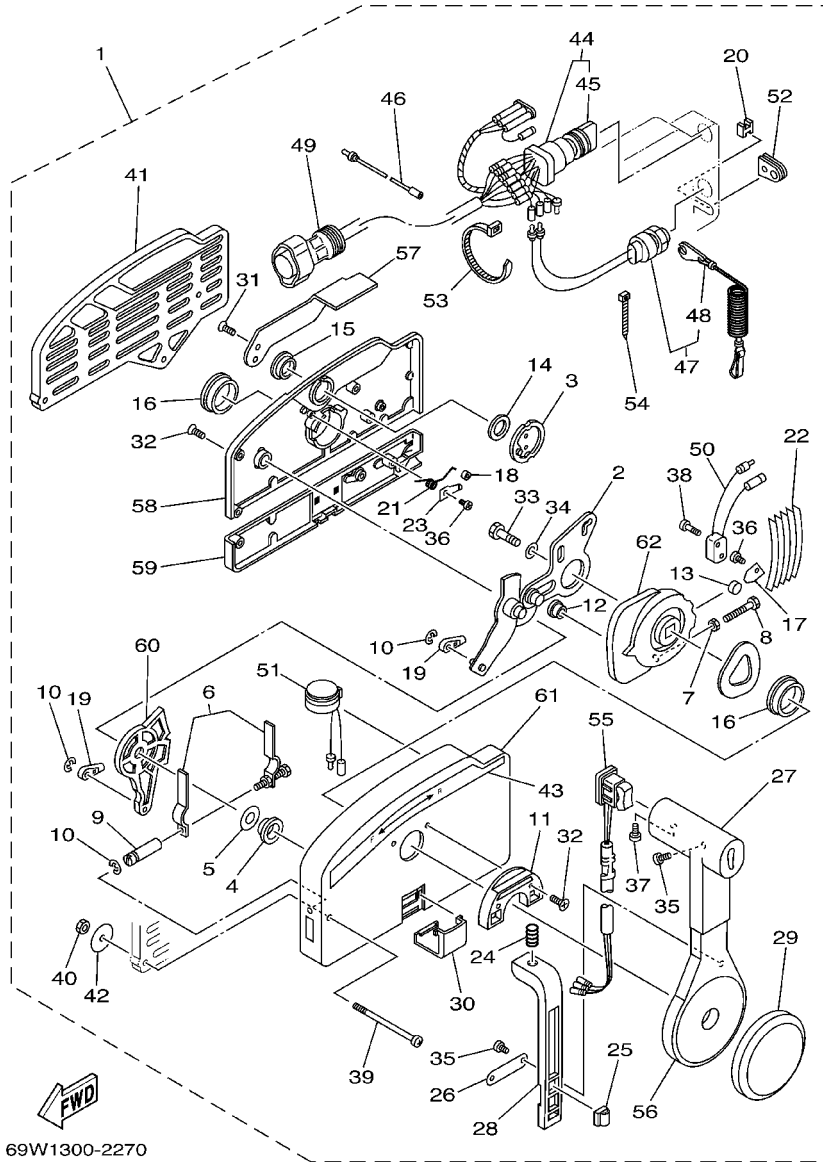


69W1300-2270

REF. NO.	PART NO. NO. PIECES	DESCRIPTION DESCRIPTION	F60A	F40C	REMARKS REMARQUES
1	703-48207-17	REMOTE CONTROL ASSY BOITIER DE COMMANDE A DISTANCE	1	1	AP WITH PT/T SW.
2	703-48261-01	.ARM, THROTTLE .BRAS, ACCELERATION	1	1	
3	703-48153-00	.SHAFT, FREE ACCEL. .AXE	1	1	
4	703-48235-00	.BUSHING .COUSSINET	1	1	
5	703-48268-00	.SPACER .ENTRETOISE	1	1	
6	703-48264-00	.THROTTLE, FRICTION .ACCELERATION	1	1	
7	95380-05600	.NUT .ECROU	1	1	
8	97380-05025	.BOLT .BOULON, HEXAGONAL	1	1	
9	703-48265-00	.SHAFT, FRICTION .AXE, COPILOTE	1	1	
10	93430-06024	.CIRCLIP	3	3	
11	703-48245-00	.CLIPS .PLATE, LOCK .PLAQUE, VERROU	1	1	
12	703-48252-00	.ROLLER, CAM .POULIE	1	1	
13	701-48248-00	.ROLLER, FREE ACCEL. .POULIE	1	1	
14	703-48198-00	.WASHER, WAVE .RONDELLE, ELASTIQUE ONDULEE	1	1	
15	703-48243-00	.BUSHING .COUSSINET	1	1	
16	703-48236-00	.BUSHING 1 .POULIE	2	2	
17	703-48189-00	.RETAINER .FLASQUE	1	1	
18	703-48234-00	.ROLLER, DETENT .POULIE	1	1	
19	703-48345-01	.CABLE END, REMOTE CONTROL 2 .CHAPE CABLE	2	2	
20	703-48358-00	.ANCHOR, CABLE .COLLIER	1	1	
21	703-48244-00	.SPRING, FREE ACCEL. .RESSORT	1	1	
22	703-48238-00	.SPRING, DETENT .RESSORT	5	5	
23	703-48246-00	.SPACER .ENTRETOISE	1	1	
24	703-48227-00	.SPRING, NEUTRAL LOCK .RESSORT	1	1	
25	703-82594-00	.CLAMP .BRIDE	1	1	WITH PT/T SW.
26	703-48226-00	.PLATE, STOPPER .PLAQUETTE	1	1	
27	703-48222-00	.GRIP, CONTROL LEVER .POIGNEE, COMMANDE LEVIER	1	1	SINGLE

FIG. 27 REMOTE CONTROL ASSY

BOITIER DE COMMANDE A DISTANCE

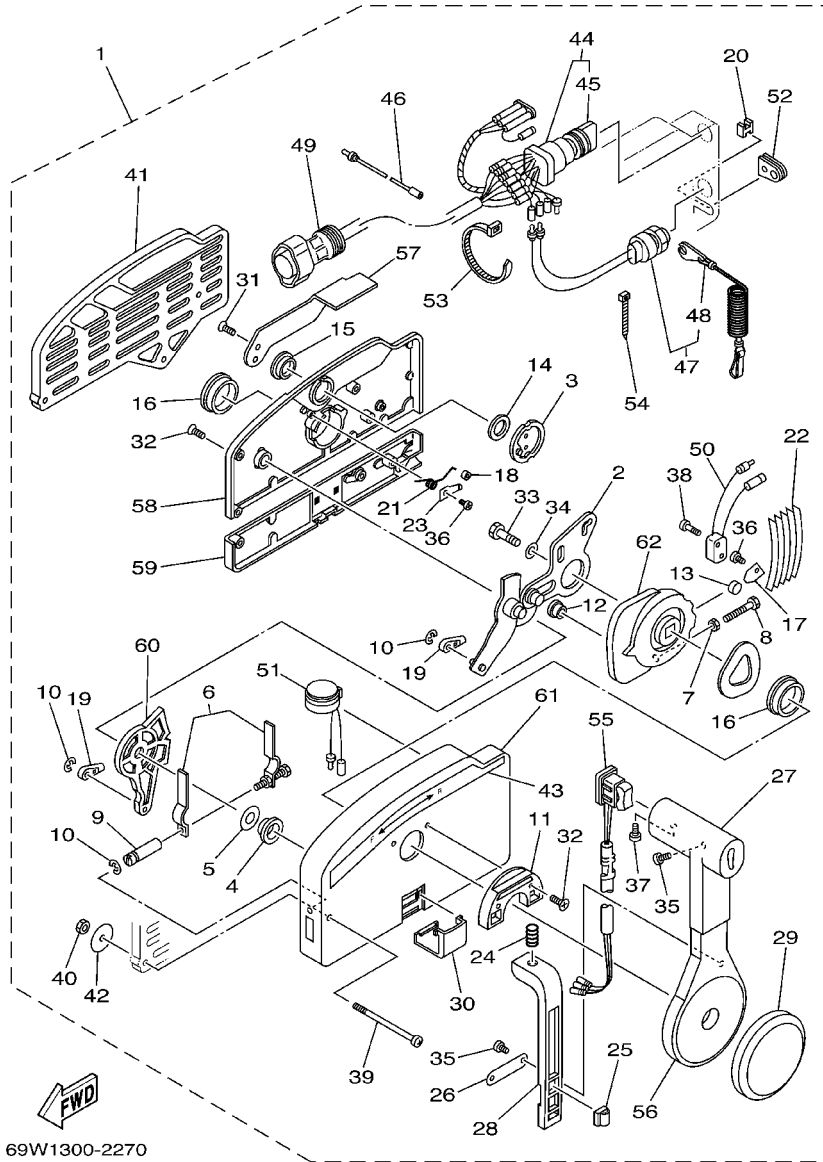


69W1300-2270

REF. NO.	PART NO. NO. PIECES	DESCRIPTION DESCRIPTION	F60A	F40C	REMARKS REMARQUES
28	703-48223-00	.LOCK, NEUTRAL .VERROU, NEUTRAL	1	1	
29	703-48225-00	.COVER .COUVERCLE	1	1	
30	703-48219-00	.COVER, LEAD .COUVERCLE	1	1	
31	703-48281-00	.SCREW .VIS	2	2	
32	703-48282-00	.SCREW .VIS	7	7	
33	97380-08030	.BOLT .BOULON, HEXAGONAL	1	1	
34	92990-08600	.WASHER, PLATE .RONDELLE, PLATE	1	1	
35	98580-04010	.SCREW, PAN HEAD .VIS	3	3	
36	98580-04006	.SCREW, PAN HEAD .VIS	2	2	
37	98580-05010	.SCREW, PAN HEAD .VIS	1	1	
38	98580-03015	.SCREW, PAN HEAD .VIS	2	2	
39	703-48291-10	.SCREW (M6) .VIS (M6)	3	3	
40	95380-06600	.NUT, HEXAGON .ECROU	3	3	
41	703-48293-10	.SPACER, REMOTE CONTROL .ENTRETOISE	1	1	SINGLE
42	701-48287-00	.WASHER .RONDELLE	3	3	
43	703-48215-00	.GRAPHIC .ADHESIF	1	1	
44	703-82510-43	.MAIN SWITCH ASSY .CONTACTEUR A CLEF COMPLET	1	1	
45	703-82577-00	.CAP, KEY .CABOCHON	1	1	
46	703-82531-00	.WIRE, LEAD .FIL	1	1	
47	688-82575-01	.ENGINE STOP SWITCH ASSY .COUPE CIRCUIT CPLT	1	1	
48	682-82556-00	.STOPPER .PLAQUETTE	1	1	
49	688-8258A-20	.EXTENSION, WIRE HARNESS .EXTENSION, FAISCEAU DE FILS	1	1	L:5M (10P)
50	703-82540-00	.NEUTRAL SWITCH ASSY .CONTACTEUR DE POINT-MORT	1	1	
51	703-83383-A0	.BUZZER .RONFLEUR	1	1	
52	703-48284-10	.GROMMET .PASSE-FIL	1	1	
53	703-82591-00	.BAND .COLLIER	3	3	
54	703-82592-00	.BAND .COLLIER	1	1	

FIG. 27 REMOTE CONTROL ASSY

BOITIER DE COMMANDE A DISTANCE



69W1300-2270

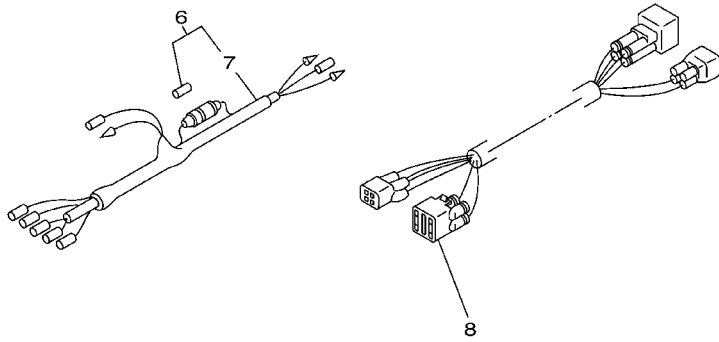
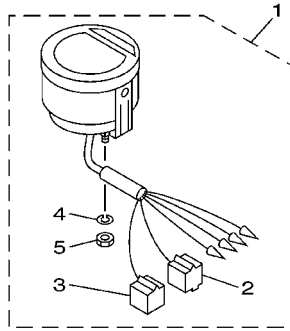
REF. NO.	PART NO. NO. PIECES	DESCRIPTION DESCRIPTION	F60A	F40C	REMARKS REMARQUES
55	703-82563-12	.TRIM & TILT SWITCH ASSY .INCLINER ET PARER COMMUTATEUR	1	1	
56	703-48221-00	.LEVER, CONTROL .LEVIER, COMMANDE	1	1	
57	703-48152-00	.KNOB, FREE ACCEL. .BOUTON	1	1	
58	703-48212-00	.BACK PLATE 1 .PLAQUETTE 1	1	1	
59	703-48213-00	.BACK PLATE 2 .PLAQUETTE 2	1	1	
60	703-48271-00	.ARM, SHIFT .BRAS	1	1	
61	703-48211-01	.HOUSING,1 .CORPS	1	1	
62	703-48232-00	.GEAR .PIGNON	1	1	



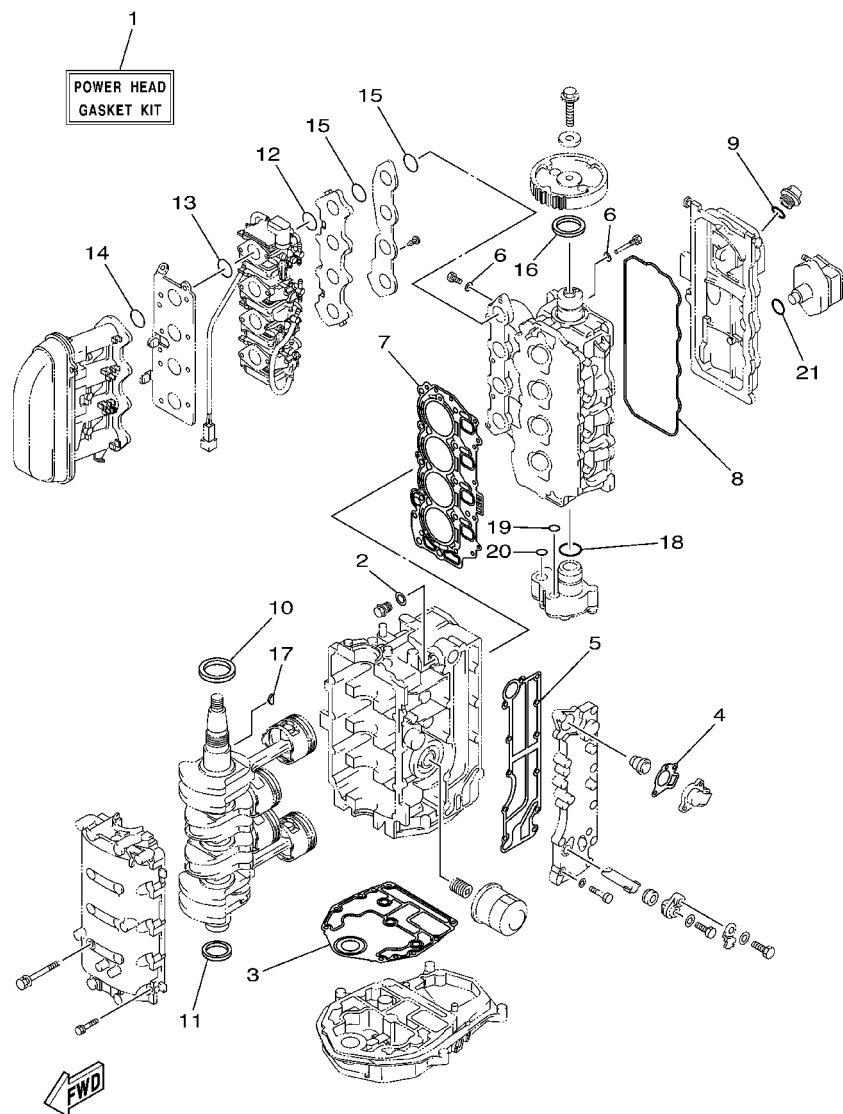
FIG. 28 METER

COMPTEUR

REF. NO.	PART NO. NO. PIECES	DESCRIPTION DESCRIPTION	F60A	F40C	REMARKS REMARQUES
1	6Y5-8350T-02	TACHOMETER ASSY COMPTE-TOURS CPLT	1	1	AP
2	9E450-04433	.CONNECTOR .CONNECTEUR	1	1	M-4-W
3	9E450-04533	.CONNECTOR .CONNECTEUR	1	1	F-4-W
4	92990-04100	.WASHER, SPRING .RONDELLE, GROWER	2	2	
5	95380-04600	.NUT .ECROU	2	2	
6	6Y5-83553-00	WIRE, LEAD FIL	1	1	AP
7	1E6-82151-00	.FUSE (10A) .FUSIBLE (10A)	1	1	
8	68F-82553-70	EXTENSION, WIRE LEAD EXTENSION, FAISCEAU	1	1	AP



69W1300-2280



69W1100-2330

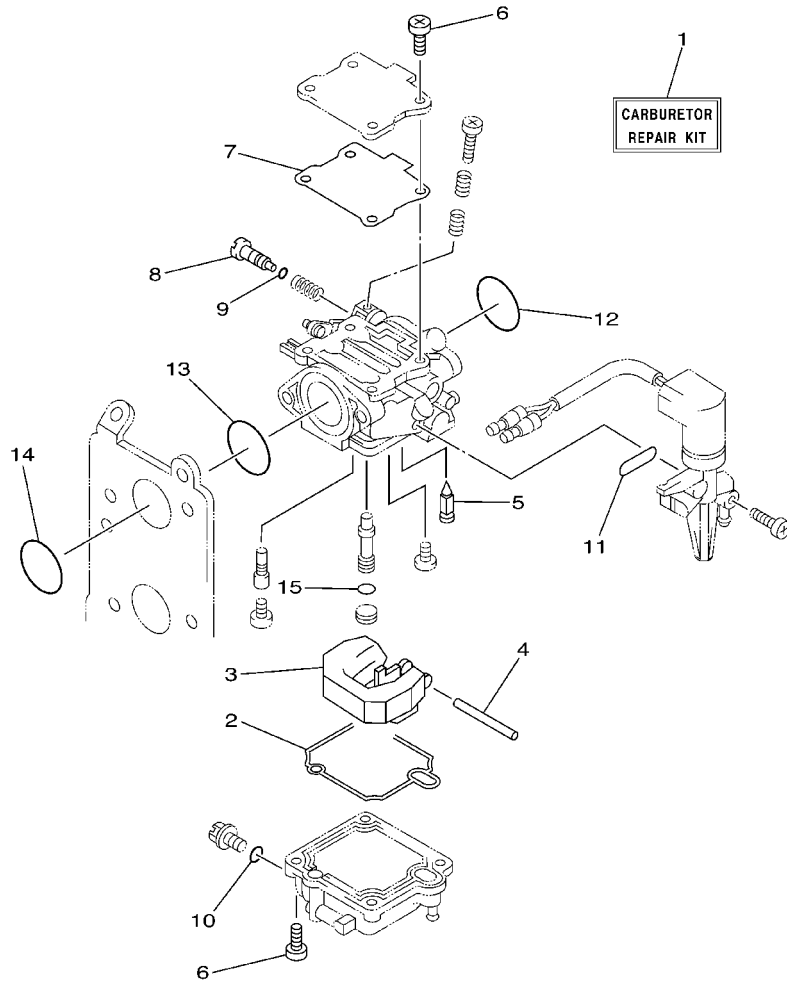
FIG. 29 REPAIR KIT 1

KITS DE REPARATION 1

REF. NO.	PART NO. NO. PIECES	DESCRIPTION DESCRIPTION	F60A	F40C	REMARKS REMARQUES
1	69W-W0001-00	POWER HEAD GASKET KIT POCHETTE DE JINTS TETE MOTRICE	1	1	
2	90430-14115	.GASKET .JOINT	1	1	
3	67C-11351-00	.GASKET, CYLINDER .JOINT, D'EMBASE	1	1	
4	62Y-12414-00	.GASKET, COVER .JOINT, COUVERCLE	1	1	
5	62Y-41114-00	.GASKET, EXHAUST OUTER COVER .JOINT, COUVERCLE D'ECHAPPEMEN	1	1	
6	90430-06014	.GASKET .JOINT	5	5	
7	69W-11181-00	.GASKET, CYLINDER HEAD 1 .JOINT, DE CULASSE 1	1	1	
8	62Y-11356-00	.SEAL, CYLINDER 2 .JOINT, SPY CYLINDRE	1	1	
9	93210-24M79	.O-RING .JOINT TORIQUE	1	1	
10	93102-43M42	.OIL SEAL .JOINT SPY	1	1	
11	93101-35002	.OIL SEAL .JOINT SPY	1	1	
12	69W-14561-00	.O-RING .JOINT TORIQUE	4	4	
13	93210-35M86	.O-RING .JOINT TORIQUE	4	4	
14	93210-38MH3	.O-RING .JOINT TORIQUE	4	4	
15	93210-35M86	.O-RING .JOINT TORIQUE	8	8	
16	93102-37M40	.OIL SEAL .JOINT SPY	1	1	
17	90280-04M06	.KEY, WOODRUFF .CLAVETTE, DEMI-LUNE	1	1	
18	93210-33MH2	.O-RING .JOINT TORIQUE	1	1	
19	93210-12MG9	.O-RING .JOINT TORIQUE	1	1	
20	93210-14515	.O-RING .JOINT TORIQUE	1	1	
21	93210-24M79	.O-RING .JOINT TORIQUE	1	1	

FIG. 30 REPAIR KIT 2

KITS DE REPARATION 2

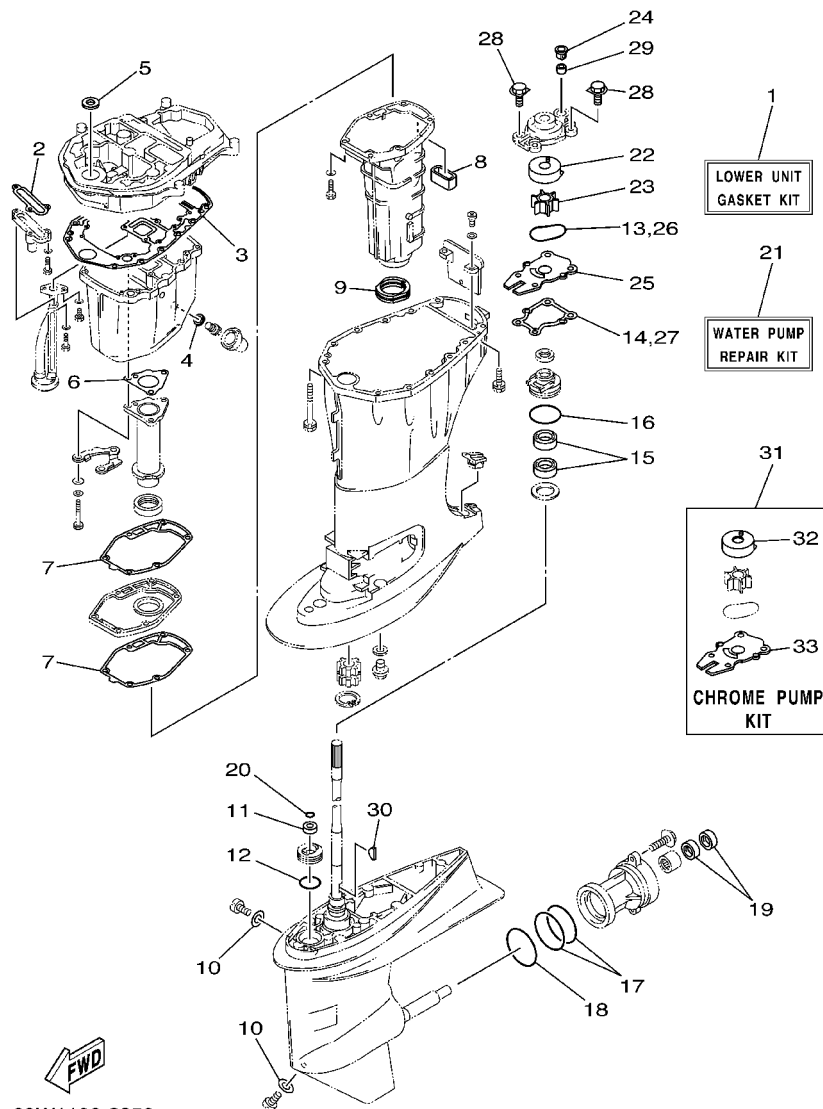


FWD  
69W1100-2340

REF. NO.	PART NO. NO. PIECES	DESCRIPTION DESCRIPTION	F60A	F40C	REMARKS REMARQUES
1	69W-W0093-10	CARBURETOR REPAIR KIT KIT DE REPARATION CARBURATEUR	1	1	
2	69W-14384-00	.GASKET, FLOAT CHAMBER .JOINT, CUVE DE FLOTTEUR	1	1	
3	6L2-14385-00	.FLOAT .FLOTTEUR	1	1	
4	6E5-14386-01	.PIN, FLOAT .AXE, FLOTTEUR	1	1	
5	62Y-14392-00	.VALVE, NEEDLE .POINTEAU	1	1	
6	62Y-14321-00	.SCREW, THROTTLE .VIS, ACCELERATEUR	8	8	
7	69W-14399-00	.VALVE, BIMETAL .CLAPET, BILAME	1	1	
8	69W-14323-00	.SCREW, AIR ADJUSTING .VIS DE DOSEUR D'AIR	1	1	
9	2T4-14397-00	.O-RING .JOINT TORIQUE	1	1	
10	652-14397-00	.O-RING .JOINT TORIQUE	1	1	
11	62Y-14398-30	.GASKET .JOINT	1	1	
12	69W-14561-00	.O-RING .JOINT TORIQUE	4	4	
13	93210-35M86	.O-RING .JOINT TORIQUE	4	4	
14	93210-38MH3	.O-RING .JOINT TORIQUE	4	4	
15	62Y-14227-00	.WASHER .RONDELLE	4	4	

FIG. 31 REPAIR KIT 3

KITS DE PEPARATION 3

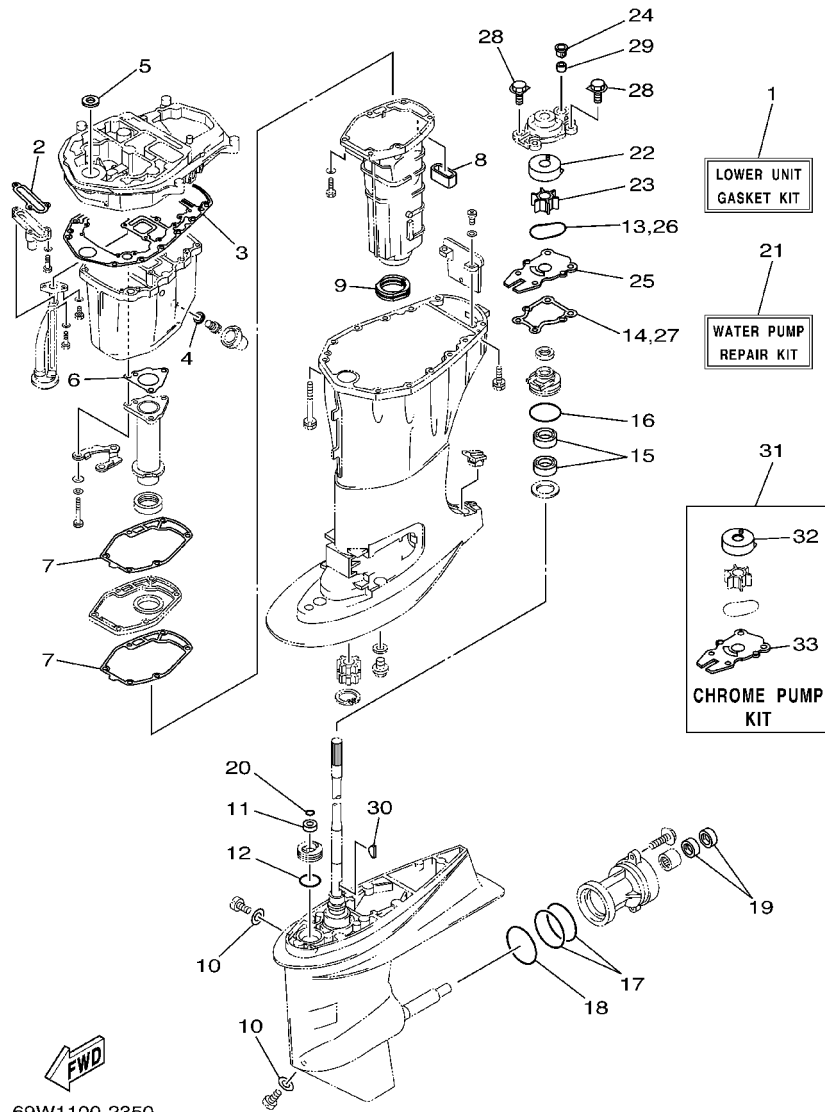


69W1100-2350

REF. NO.	PART NO. NO. PIECES	DESCRIPTION DESCRIPTION	F60A	F40C	REMARKS REMARQUES
1	69W-W0001-20	LOWER UNIT GASKET KIT POCHETTE DE JOINTS EMBASE	1	1	
2	62Y-13475-00	.GASKET .JOINT	1	1	
3	69W-15312-00	.GASKET, OIL PAN .JOINT DE VENTILATEUR D'HUILE	1	1	
4	90430-14M09	.GASKET .JOINT	1	1	
5	93103-18011	.OIL SEAL .JOINT SPY	1	1	
6	64J-41133-10	.GASKET, EXHAUST MANIFOLD 1 .JOINT, PIPE D'ECHAPPEMENT	1	1	
7	62Y-41134-01	.GASKET, EXHAUST MANIFOLD .JOINT, PIPE D'ECHAPPEMENT	2	2	
8	62Y-45127-00	.SEAL .JOINT	1	1	
9	67C-45123-00	.GASKET, MUFFLER .JOINT, POT DE DETENTE	1	1	
10	90430-08020	.GASKET .JOINT	2	2	
11	93106-09014	.OIL SEAL .JOINT SPY	1	1	
12	93210-33MG4	.O-RING .JOINT TORIQUE	1	1	
13	93210-59MG7	.O-RING .JOINT TORIQUE	1	1	
14	63D-44316-00	.GASKET, WATER PUMP .JOINT, POMPE A EAU	1	1	
15	93101-25M57	.OIL SEAL .JOINT SPY	2	2	
16	93210-48MG8	.O-RING .JOINT TORIQUE	1	1	
17	93210-74MG5	.O-RING .JOINT TORIQUE	2	2	
18	93210-69MG6	.O-RING .JOINT TORIQUE	1	1	
19	93101-22M00	.OIL SEAL .JOINT SPY	2	2	
20	93210-07003	.O-RING .JOINT TORIQUE	1	1	
21	63D-W0078-01	WATER PUMP REPAIR KIT KIT DE REPARATION DE LA POMPE	1	1	
22	63D-44322-00	.INSERT, CARTRIDGE .CUVETTE	1	1	
23	6H3-44352-00	.IMPELLER .TURBINE	1	1	
24	63D-44312-00	.COVER, WATER PUMP HOUSING .COUVERCLE	1	1	
25	63D-44323-00	.OUTER PLATE, CARTRIDGE .PLAQUE EXTERIEURE	1	1	
26	93210-59MG7	.O-RING .JOINT TORIQUE	1	1	
27	63D-44316-00	.GASKET, WATER PUMP .JOINT, POMPE A EAU	1	1	

FIG. 31 REPAIR KIT 3

KITS DE PEARATION 3



REF. NO.	PART NO. NO. PIECES	DESCRIPTION DESCRIPTION	F60A	F40C	REMARKS REMARQUES
28	90119-08M15	.BOLT, WITH WASHER .BOULON, AVEC RONDELLE	4	4	
29	663-44366-00	.DAMPER, WATER SEAL .JOINT, TUBE D'EAU	1	1	
30	90280-03024	.KEY, WOODRUFF .CLAVETTE, DEMI-LUNE	1	1	
31	63D-W0078-0A	CHROME PUMP KIT KIT DE POMPE A EAU CHROME	1	1	
32	63D-44322-40	.INSERT, CARTRIDGE .CUVETTE	1	1	
33	63D-44323-40	.OUTER PLATE, CARTRIDGE .PLAQUE EXTERIEURE	1	1	
-----					
-----					
-----					
-----					
-----					
-----					
-----					
-----					

NUMERICAL INDEX  
INDEX NUMERIQUE

PART NO. NO. PIECES	REF. NO.	PART NO. NO. PIECES	REF. NO.	PART NO. NO. PIECES	REF. NO.	PART NO. NO. PIECES	REF. NO.	PART NO. NO. PIECES	REF. NO.	PART NO. NO. PIECES	REF. NO.
69W-W0001-00	29 - 1	62Y-11650-10	3 - 3	62Y-14227-00	30 - 15	69W-14561-00	29 - 12	62Y-24410-03	9 - 18	69W-42615-00	1 - 14
69W-W0001-20	31 - 1	62Y-11654-00	3 - 4	69W-14271-00	6 - 32		30 - 12	62Y-24411-02	9 - 21	61N-42628-00	1 - 15
69W-W0070-00	1 - 11	62Y-11656-30	3 - 5	62Y-14291-30	6 - 25	62Y-14567-30	7 - 30	62Y-24413-01	9 - 19	62Y-42651-00	1 - 4
63D-W0078-0A	31 - 31	62Y-11656-40	3 - 5	62Y-14321-00	7 - 13	62Y-14567-40	7 - 30	62Y-24421-01	9 - 20	67C-42652-00	1 - 6
63D-W0078-01	31 - 21	62Y-11656-50	3 - 5		30 - 6	64J-14585-00	6 - 15	62Y-24422-00	9 - 32	62Y-42677-50	1 - 9
69W-W009A-00-1S	4 - 1	62Y-11656-60	3 - 5	62Y-14321-10	7 - 22	62Y-14597-00	7 - 34	62Y-24423-00	9 - 22	69W-42677-00	1 - 9
69W-W009B-00-1S	2 - 1	69W-12111-00	5 - 1	69W-14321-00	7 - 37	69W-14711-00-5B	20 - 19	62Y-24444-01	9 - 25	62Y-42678-50	1 - 10
69W-W0093-10	30 - 1	51Y-12114-00	5 - 4	69W-14323-00	7 - 20	69W-14901-01	7 - 1	62Y-24452-00	9 - 29	69W-42678-00	1 - 10
63D-W4434-00	22 - 30	62Y-12116-00	5 - 3		30 - 8	69W-14902-01	7 - 2	62Y-24454-00	9 - 24	69W-42681-00	1 - 12
69W-11111-00-1S	4 - 2	30X-12117-00	5 - 5	6A0-14325-00	9 - 27	69W-14903-01	7 - 3	68V-24469-00	9 - 10	69W-42682-00	1 - 13
62Y-11119-00	4 - 28	30X-12118-00	5 - 6	650-14327-01	6 - 2	60K-14904-01	7 - 4	62Y-24471-00	9 - 26	67C-42710-12-4D	14 - 1
62Y-11133-30	4 - 3	51Y-12119-00	5 - 7	69W-14327-01	7 - 35	69W-14904-01	7 - 4	65W-24474-00	9 - 34	62Y-42715-01	15 - 8
62Y-11168-00	4 - 23	69W-12121-00	5 - 2	62Y-14334-00	7 - 21	69W-15100-00-1S	2 - 2	68W-24521-00	9 - 8	62Y-42716-00	14 - 5
69W-11181-00	4 - 17	62Y-12138-60	4 - 35	69W-14341-00	7 - 16	62Y-1531A-00	6 - 41	64J-24560-00	9 - 6	65W-42717-00	14 - 6
	29 - 7	62Y-12146-00	5 - 8	64J-14342-20	7 - 18	64J-15311-01-5B	21 - 9	68V-24563-00	9 - 7	65W-42724-10	14 - 42
62Y-11191-01-1S	4 - 21	62Y-12151-00	5 - 9	69W-14343-62	7 - 17	69W-15312-00	21 - 11	62Y-24566-00	9 - 11	62Y-42725-30	14 - 8
62Y-11325-00	2 - 24	62Y-12158-00	5 - 11	64J-14349-11	6 - 18		31 - 3	6YK-24610-00	24 - 3	688-42726-10	14 - 22
	4 - 5	64J-12159-00	5 - 10	64J-14349-40	6 - 28	67C-15316-00	21 - 13	6YL-24641-00	24 - 4	6H3-42727-00	14 - 26
	20 - 2	62Y-12171-00	8 - 1	69W-14349-00	6 - 19	62Y-1532B-00	6 - 26	62Y-28100-00	9 - 38	62Y-42727-00	14 - 9
66M-11327-00-94	2 - 26	62Y-12216-00	5 - 14	69W-14349-10	6 - 20	67C-15362-00	21 - 18	6A1-28176-00	14 - 52	68U-42727-00	14 - 25
	4 - 7	62Y-12231-00	5 - 15	66M-14355-00	7 - 19	6G8-15363-00	4 - 33	62Y-28199-7C-A0	9 - 39	67C-42738-00-4D	14 - 7
	20 - 4	62Y-12238-00	5 - 12	69W-14369-00	6 - 1	62Y-15373-10	6 - 42	62Y-28199-7C-B0	9 - 39	67C-42741-10-4D	14 - 28
66M-11328-00	2 - 25	62Y-12279-00	5 - 13	69W-14380-01	7 - 31	1UF-22434-00	18 - 17	62Y-28199-8C-A0	9 - 40	67C-42815-00-4D	14 - 11
	4 - 6	6G8-12411-02	2 - 11	69W-14380-11	7 - 31	62Y-22434-00	18 - 50	62Y-28199-8C-B0	9 - 40	67C-42816-01	14 - 16
	20 - 3	6H3-12413-00-1S	2 - 12	69W-14381-00	7 - 5	62Y-22471-00	18 - 11	62Y-41113-20-1S	2 - 14	69W-43111-00-4D	16 - 1
67C-11351-00	2 - 10	62Y-12414-00	2 - 13	69W-14381-10	7 - 6	69W-23153-00	6 - 13	62Y-41114-00	2 - 22	69W-43112-00-4D	16 - 2
	29 - 3		29 - 4	69W-14381-20	7 - 7	6YK-24201-01	24 - 1		29 - 5	6E5-43126-02	16 - 32
62Y-11356-00	4 - 26	66M-12535-00	2 - 27	69W-14381-30	7 - 8	6YK-24260-01	24 - 5	64J-41116-00	20 - 14	63D-43131-01	16 - 11
	29 - 8		4 - 8	62Y-14383-30	7 - 24	6YL-24268-01	24 - 2	69W-41131-00	20 - 11	6G5-43144-00	16 - 25
62Y-11372-01	2 - 15		20 - 5	69W-14384-00	7 - 9	6G1-24304-02	9 - 1	64J-41133-10	20 - 13	66T-43144-00	14 - 18
69W-11411-00	3 - 1	69W-12535-00	14 - 44		30 - 2	6YL-24306-52	24 - 8		31 - 6	6E5-43145-01	25 - 9
62Y-11416-30	3 - 2	68T-12572-00	14 - 43	6L2-14385-00	7 - 10	69W-24311-00	7 - 28	62Y-41134-01	20 - 22	6G5-43145-01	16 - 15
62Y-11416-40	3 - 2	6R3-12580-00	14 - 49		30 - 3	62Y-24312-00	6 - 7		31 - 7	6G5-43148-00	16 - 21
62Y-11416-50	3 - 2	62Y-13131-01	9 - 23	6E5-14386-01	7 - 11	67C-24312-00	14 - 47	69W-41137-01-94	20 - 1	688-43160-01	16 - 26
62Y-11416-60	3 - 2	69W-13300-00	8 - 16		30 - 4	62Y-24313-30	6 - 8	6F5-41237-00	15 - 20	688-43165-00	16 - 27
62Y-11536-10	8 - 12	62Y-13411-00	21 - 5	62Y-14392-00	7 - 12	62Y-24313-40	6 - 9	662-41237-01	15 - 22	6H5-43181-03	16 - 16
62Y-11537-10	8 - 2	67F-13434-02	1 - 16		30 - 5	62Y-24313-50	6 - 10	60K-41241-00	15 - 21	6H5-43185-03	16 - 17
6H4-11545-00	10 - 17	62Y-13437-61	10 - 20	2T4-14397-00	7 - 23	62Y-24313-61	6 - 11	69W-41241-00	15 - 21	63D-43311-13-4D	16 - 9
62Y-11557-00	8 - 13	5GH-13440-00	2 - 32		30 - 9	62Y-24313-70	6 - 12	62Y-42154-00	15 - 25	69W-4380F-00	19 - 9
62Y-11575-00	21 - 1	62Y-13444-50	14 - 51	652-14397-00	7 - 25	62Y-24313-90	7 - 33	69W-42159-00	15 - 24	69W-4380K-00	18 - 2
62Y-11590-10	8 - 7	62Y-13475-00	21 - 2		30 - 10	69W-24313-80	6 - 14	69W-42171-00	15 - 26	69W-43800-00-4D	18 - 1
67C-11603-00	3 - 7		31 - 2	62Y-14398-30	7 - 29	62Y-24314-00	6 - 31	60K-42335-00	15 - 31	62X-43807-00	19 - 4
67C-11604-00	3 - 7	69W-13586-00	6 - 3		30 - 11	6YL-24329-00	24 - 7	62Y-42335-20	15 - 31	69W-43805-00	19 - 3
67C-11605-00	3 - 7	69W-14115-00	7 - 38	69W-14399-00	7 - 15	61N-24329-00	14 - 27	69W-42510-00-4D	17 - 1	62X-43807-00	19 - 8
69W-11631-00-97	3 - 6	62Y-14157-30	7 - 14		30 - 7	62Y-24374-01	9 - 31	624-42542-00	12 - 28	69W-4381B-00	18 - 13
62Y-11633-00	3 - 8	62Y-14212-00	7 - 26	69W-14440-00	6 - 4	62Y-24378-00	6 - 23	60K-42610-00-4D	1 - 1	62X-43810-01	18 - 3
69W-11635-00	3 - 6	69W-14212-00	7 - 36	62Y-14485-00	4 - 22		6 - 29	69W-42610-00-4D	1 - 1	6H1-43816-00	18 - 56
69W-11636-00	3 - 6	62Y-14227-00	7 - 32	69W-14561-00	6 - 16		2 - 17	67C-42613-00-4D	1 - 2	62Y-43816-00	18 - 41

NUMERICAL INDEX  
INDEX NUMERIQUE

PART NO. NO. PIECES	REF. NO.	PART NO. NO. PIECES	REF. NO.	PART NO. NO. PIECES	REF. NO.	PART NO. NO. PIECES	REF. NO.	PART NO. NO. PIECES	REF. NO.	PART NO. NO. PIECES	REF. NO.
62Y-43818-00	16 - 36	62Y-44118-00	15 - 9	69W-45300-00-4D	22 - 1	6H5-45952-00-EL	23 - 25	703-48284-10	27 - 52	703-82119-00	17 - 32
69W-4382L-00	18 - 42	62Y-44120-01	15 - 7	69W-45301-00-4D	22 - 2	663-45954-01-EL	23 - 25	701-48287-00	27 - 42	67C-82127-10	17 - 41
6H1-43829-00	18 - 63	69W-44121-00	15 - 1	69W-45318-00	20 - 32	663-45956-01-EL	23 - 25	703-48291-10	27 - 39	63D-82148-00	16 - 3
69W-43830-00	18 - 21	688-44122-00	15 - 18	63D-45321-00	22 - 14	663-45970-60-98	23 - 25	703-48293-10	27 - 41	1E6-82151-00	28 - 7
6H1-43831-10	18 - 19	62Y-44135-00	15 - 28	688-45341-10	22 - 9	663-45972-60-98	23 - 25	701-48310-90	26 - 2	663-82151-00	12 - 32
6H1-4384F-10	18 - 33	63D-44144-00	22 - 52	63D-45344-00	22 - 34	663-45974-02-98	23 - 25	701-48320-00	26 - 2	6G5-82152-00	12 - 33
69A-4384F-00	18 - 24	62Y-44151-00	22 - 51	63D-45361-02-4D	22 - 43	663-45974-60-98	23 - 25	701-48320-20	26 - 2	69W-82181-00	19 - 7
69W-4384G-00	18 - 46	63D-44311-00	22 - 21	67C-45371-00	23 - 12	663-45976-00-98	23 - 25	701-48320-50	26 - 2	6A0-82317-00	12 - 27
62X-4384H-00	18 - 16	63D-44312-00	23 - 19	63D-45375-00	23 - 6	663-45978-00-98	23 - 25	69W-48344-00	15 - 34	6E7-82317-00	14 - 24
69J-4384M-00	18 - 23			663-45376-00-94	23 - 5	663-45987-02	23 - 20	703-48345-01	27 - 19	663-82317-01	10 - 15
69J-43841-00	18 - 22	63D-44316-00	22 - 27	6E5-45378-00	22 - 17	66T-45997-00	23 - 21	703-48358-00	27 - 20	6G8-82370-30	11 - 8
69J-43843-00	18 - 37			69W-45501-00	22 - 36	64J-46132-10	20 - 12	65W-48511-00	17 - 43	69W-82377-00	14 - 50
6H1-43844-10	18 - 35			6H4-45536-00	22 - 4	62Y-46241-00	8 - 6	62Y-48538-00	15 - 36	64J-82504-00	11 - 17
69J-43844-00	18 - 54	63D-44322-00	22 - 22	69W-45551-00	22 - 37	703-48152-00	27 - 57	65W-61350-00	25 - 1	69W-82509-00	6 - 27
62Y-43845-00	18 - 61			69W-45560-00	22 - 39	703-48153-00	27 - 3	65W-61351-00	25 - 2	703-82510-43	27 - 44
69J-43851-00	18 - 31	63D-44322-40	31 - 32	663-45567-01-10	22 - 41	703-48189-00	27 - 17	62Y-81337-11	10 - 13	703-82531-00	27 - 46
69J-43853-00	18 - 29	63D-44323-00	22 - 26	663-45567-01-12	22 - 41	703-48198-00	27 - 14	6K7-81338-01	10 - 14	703-82540-00	27 - 50
69W-43854-00	18 - 47			663-45567-01-15	22 - 41	703-48207-17	26 - 1	69W-81800-00	13 - 1	62Y-82544-00	6 - 30
69J-43855-00	18 - 32	63D-44323-40	31 - 33	663-45567-01-18	22 - 41			6N7-81801-00	13 - 8	68F-82553-70	28 - 8
69W-43856-00	18 - 34	63D-44341-00	22 - 31	663-45567-01-30	22 - 41	703-48211-01	27 - 61	69W-81807-00	13 - 11	682-82556-00	27 - 48
65W-4386A-00	18 - 28	6H3-44352-00	22 - 23	663-45567-01-40	22 - 41	703-48212-00	27 - 58	61A-81809-00	13 - 3	62Y-82560-01	11 - 18
62X-4386K-00	19 - 10			663-45567-01-50	22 - 41	703-48213-00	27 - 59	6N7-81810-00	13 - 5	63D-82563-10	12 - 37
62X-43861-00	18 - 4	62Y-44361-00	23 - 1	62Y-45571-00	22 - 42	703-48215-00	27 - 43	6N7-81813-00	13 - 9	703-82563-12	27 - 55
62X-43862-00	18 - 5	663-44366-00	23 - 18	63D-45577-00-10	22 - 46	703-48219-00	27 - 30	6E5-8182A-10	13 - 17	6E3-8257H-00	14 - 53
62X-43865-00	18 - 64			63D-45577-00-12	22 - 46	703-48221-00	27 - 56	6E5-8182E-10	13 - 15	688-82575-01	27 - 47
62Y-4387G-00	18 - 52	663-44367-00	23 - 2	63D-45577-00-15	22 - 46	703-48222-00	27 - 27	6E5-8182F-10	13 - 16	703-82577-00	27 - 45
62Y-4387J-00	18 - 49	6H3-44391-01	14 - 21	63D-45577-00-18	22 - 46	703-48223-00	27 - 28	6K7-8182G-10	13 - 6	688-8258A-20	27 - 49
62X-43871-00	18 - 7	69W-44514-00-4D	17 - 10	63D-45577-00-30	22 - 46	703-48225-00	27 - 29	6E5-8182K-10	13 - 18	6E5-82587-00	12 - 38
62Y-43871-00	18 - 51	69W-44526-01	17 - 12	63D-45577-00-40	22 - 46	703-48226-00	27 - 26	6N7-81820-00	13 - 10	6E9-82588-00	11 - 19
6H1-43875-00	18 - 60	69W-44551-00-4D	17 - 16	63D-45577-00-50	22 - 46	703-48227-00	27 - 24	62Y-81822-01-94	11 - 9	69W-82590-00	12 - 31
62X-43875-00	18 - 18	67C-44552-01-4D	17 - 21	663-45587-01-10	22 - 5	703-48232-00	27 - 62	61A-81824-00	13 - 4	703-82591-00	27 - 53
67F-43875-00	18 - 12	67C-44553-00-4D	17 - 18	663-45587-01-12	22 - 5	703-48234-00	27 - 18	6K7-81826-10	13 - 14	703-82592-00	27 - 54
62X-4388A-00	18 - 10	69W-44555-00-4D	17 - 24	663-45587-01-15	22 - 5	703-48235-00	27 - 4	6N7-81830-00	13 - 13	688-82594-00	12 - 34
69W-43880-00	19 - 2	69W-44575-00	17 - 17	663-45587-01-18	22 - 5	703-48236-00	27 - 16	6N7-81840-00	13 - 7	703-82594-00	27 - 25
69W-43881-00	19 - 13	67C-45111-21-4D	20 - 25	663-45587-01-30	22 - 5	703-48238-00	27 - 22	6N7-81850-10	13 - 2	703-83383-A0	27 - 51
6H1-43883-00	18 - 25	67C-45123-00	20 - 24	663-45587-01-40	22 - 5	703-48243-00	27 - 15	6N7-81857-00	13 - 12	6Y5-8350T-02	28 - 1
62X-43888-00	19 - 1			663-45587-01-50	22 - 5	703-48244-00	27 - 21	6G1-81941-10	12 - 13	6Y5-83553-00	28 - 6
69J-4389J-00	18 - 30	62Y-45127-00	20 - 23	63D-45611-00	22 - 55	703-48245-00	27 - 11	6L2-81945-00	12 - 15	6E5-83558-00	17 - 40
	18 - 57		31 - 8	62Y-45631-00	22 - 57	703-48246-00	27 - 23	62Y-81948-00	12 - 26	6E5-83558-10	22 - 19
62Y-43891-00	19 - 6	67C-45151-00	20 - 28	67C-45633-00	22 - 62	701-48248-00	27 - 13	6H2-81949-01	12 - 22	62Y-83614-00	12 - 39
62Y-43892-00	19 - 5	6H3-45155-00	20 - 31	663-45634-00	22 - 58	703-48252-00	27 - 12	61A-81949-00	12 - 23	6A1-83625-41	10 - 21
69J-43893-00	18 - 53	69W-45181-00-5B	20 - 18	63D-45635-00	22 - 60	703-48261-01	27 - 2	6H1-81950-00	12 - 18	6A1-83625-51	10 - 22
69J-43894-00	18 - 48	63D-45214-00	22 - 10	663-45930-00-98	23 - 25	703-48264-00	27 - 6	6G1-81952-00	12 - 14	62Y-83626-00	11 - 22
62X-43899-00	18 - 14	63D-45215-00	22 - 11	6H5-45943-00-EL	23 - 25	703-48265-00	27 - 9	64J-81960-00	12 - 5	63D-83672-01	17 - 31
69W-43899-00	18 - 65	65W-45251-00	16 - 5	69W-45943-00-EL	23 - 25	703-48268-00	27 - 5	62Y-82105-00	12 - 11	64J-85510-00	10 - 2
62Y-44112-00	15 - 10		16 - 7	6H5-45945-00-EL	23 - 25	703-48271-00	27 - 60	6E5-82117-01	12 - 12	69W-85540-00	12 - 1
62Y-44116-01	15 - 32		16 - 30	69W-45947-00-EL	23 - 25	703-48281-00	27 - 31	682-82119-01	12 - 24	69W-85550-10	10 - 1
62Y-44117-01-4D	15 - 2	67C-45251-00	23 - 15	663-45949-01-EL	23 - 25	703-48282-00	27 - 32	703-82119-00	12 - 36	62Y-85561-00-94	10 - 3

NUMERICAL INDEX  
INDEX NUMERIQUE

PART NO. NO. PIECES	REF. NO.	PART NO. NO. PIECES	REF. NO.	PART NO. NO. PIECES	REF. NO.	PART NO. NO. PIECES	REF. NO.	PART NO. NO. PIECES	REF. NO.	PART NO. NO. PIECES	REF. NO.
62Y-85570-00	11 - 1	90179-06M24	1 - 3	90386-22M15	16 - 12	90465-13M11	12 - 21	92995-05600	4 - 10	93102-43M42	29 - 10
62Y-85580-00	10 - 5	90179-06M28	14 - 39	90386-30M60	17 - 6	90465-13M18	17 - 34		20 - 7	93103-18011	20 - 10
62Y-85599-00	11 - 15	90185-08045	17 - 13	90386-30M77	17 - 4	90465-13M24	12 - 25	92995-06100	11 - 6		31 - 5
9E450-04433	28 - 2	90185-09M01	25 - 4	90386-30M78	17 - 3		12 - 35		12 - 3	93106-09014	22 - 15
9E450-04533	28 - 3	90185-10051	17 - 8	90386-90M90	15 - 14	90465-13M36	6 - 22		12 - 7		31 - 11
90101-06020	14 - 38	90185-22M11	16 - 14	90387-06M15	6 - 35	90465-13M97	10 - 9		14 - 41	93210-064A5	18 - 55
	16 - 6	90201-06015	20 - 17	90387-06M43	14 - 35	90467-08M18	2 - 21	92995-06600	2 - 31	93210-07003	22 - 53
	16 - 8	90201-08M04	16 - 38	90387-06M45	15 - 29	90467-09M17	9 - 5		4 - 12		31 - 20
	16 - 31	90201-083J8	19 - 15	90387-06M70	6 - 6		9 - 16		4 - 30	93210-08391	18 - 38
90101-08M15	17 - 11	90201-10M06	8 - 4	90387-06060	14 - 4	90467-10M04	9 - 17		6 - 37	93210-09165	18 - 62
90101-09M01	25 - 7	90201-10M20	15 - 15	90387-10M42	25 - 6		9 - 37		6 - 39	93210-12MG9	8 - 18
90101-12M65	16 - 41		25 - 3	90387-18002	16 - 39	90468-18008	15 - 17		6 - 44		29 - 19
90105-08M61	22 - 44	90201-10M63	25 - 8	90387-18003	16 - 40		15 - 35		9 - 3	93210-14515	8 - 19
90109-06M30	15 - 33	90201-12M07	14 - 15	90389-22M01	23 - 22	90480-09M12	14 - 3		9 - 36		29 - 20
90109-06M64	8 - 11	90201-12M16	12 - 29	90401-20M00	2 - 33	90480-12M25	21 - 10		11 - 7	93210-16275	25 - 10
90109-06M65	4 - 15		17 - 27	90430-06014	4 - 14	90480-12072	10 - 16		11 - 21	93210-18397	18 - 59
90109-06M80	14 - 33	90201-12426	16 - 43		4 - 16	90480-13M24	14 - 34		12 - 4	93210-24M79	4 - 34
	14 - 46	90201-13M19	17 - 29		29 - 6	90480-25161	11 - 4		12 - 8		9 - 33
90109-06M81	14 - 10	90201-21M18	10 - 19	90430-08020	22 - 8	90501-12082	15 - 12		12 - 10		29 - 9
90109-06M86	12 - 40	90201-22M03	16 - 13		31 - 10	90501-18001	22 - 59		12 - 17		29 - 21
	14 - 19	90201-22M05	17 - 30	90430-08143	4 - 31	90502-16M02	16 - 29		12 - 20	93210-29M94	17 - 5
90109-06047	1 - 7	90201-22008	22 - 56	90430-08209	7 - 39	90506-14M24	16 - 23		15 - 4	93210-29375	18 - 6
90109-08M63	5 - 16	90201-27M00	22 - 35	90430-12072	23 - 4	90506-18M40	14 - 20		15 - 6		18 - 20
90109-12MA3	17 - 25	90201-30M00	17 - 2	90430-14M09	20 - 35	90508-20018	8 - 8		20 - 16	93210-32738	9 - 9
90116-08M14	11 - 12	90202-07M07	15 - 19		21 - 15	91318-05008	18 - 44		20 - 21	93210-33MG4	22 - 16
90116-10M28	17 - 7	90202-12060	23 - 3		31 - 4	91318-05020	18 - 43		21 - 17		31 - 12
90119-06MA3	4 - 20	90202-21100	17 - 28	90430-14115	2 - 9	91318-06040	18 - 58	92995-08100	17 - 15	93210-33MH2	8 - 17
90119-06MA5	2 - 23	90206-12052	14 - 14		29 - 2	91490-16010	15 - 27		17 - 23		29 - 18
90119-06M08	14 - 2	90249-06M19	16 - 22	90445-07ME8	22 - 18	91490-20015	15 - 16		23 - 14	93210-35M86	6 - 17
90119-06025	8 - 20	90249-07M29	8 - 9	90445-07M53	17 - 39	91490-30025	23 - 24		23 - 17		6 - 34
90119-08M01	2 - 4	90250-06023	22 - 61	90445-09068	2 - 16	91690-30012	16 - 28	92995-08600	9 - 13		29 - 13
90119-08M15	22 - 29	90266-06M02	1 - 5	90445-09095	2 - 18	91690-30020	16 - 20		11 - 11		29 - 15
	31 - 28	90280-03024	22 - 25	90445-09105	2 - 19	92903-06600	2 - 6		13 - 20		30 - 13
90119-08M76	13 - 21		31 - 30	90445-10M48	9 - 15		20 - 9		17 - 20	93210-38MH3	6 - 24
90119-08M77	13 - 22	90280-04M06	8 - 15	90445-10020	9 - 4		21 - 4	92995-10100	23 - 9		29 - 14
90119-08M79	20 - 26		29 - 17	90446-17M91	17 - 36		21 - 7	92995-10600	17 - 44		30 - 14
90119-08M82	20 - 27	90338-04M17	6 - 33	90464-07M41	11 - 3	92907-04600	4 - 25		23 - 10	93210-44383	18 - 8
90119-08M84	23 - 11	90340-08002	22 - 7	90464-09M13	14 - 23	92990-04100	28 - 4	92995-12200	16 - 42	93210-48MG8	22 - 33
90119-09M00	4 - 19	90340-14M06	2 - 8	90464-09M49	14 - 36	92990-05100	10 - 7	93101-22M00	22 - 50		31 - 16
90142-05M06	22 - 12		20 - 34	90465-06M86	17 - 37	92990-05600	10 - 8		31 - 19	93210-48214	18 - 9
90157-05M16	24 - 6		21 - 14	90465-06M90	11 - 2		20 - 30	93101-25M57	22 - 32	93210-52449	19 - 16
90159-06M08	11 - 16	90344-51003	2 - 7	90465-11M10	2 - 20	92990-06100	14 - 31		31 - 15	93210-59MG7	22 - 24
90167-06002	14 - 45	90386-10M16	16 - 18		6 - 21	92990-06600	10 - 11	93101-35002	3 - 11		31 - 13
90170-09M03	25 - 5	90386-10025	16 - 19		14 - 37		14 - 32		29 - 11		31 - 26
90170-12138	22 - 38	90386-12MA2	14 - 13		14 - 48		14 - 40	93102-08414	19 - 14	93210-69MG6	22 - 48
90170-20137	10 - 18	90386-12M37	14 - 12		17 - 35	92990-08100	11 - 14	93102-37M40	8 - 21		31 - 18
90170-35M32	8 - 14	90386-18M35	16 - 34		17 - 38	92990-08600	27 - 34		29 - 16	93210-74MG5	22 - 47
90171-16011	23 - 23	90386-18M92	16 - 33		22 - 20	92995-05600	2 - 29	93102-43M42	3 - 10		31 - 17



NUMERICAL INDEX  
INDEX NUMERIQUE

PART NO. NO. PIECES	REF. NO.	PART NO. NO. PIECES	REF. NO.	PART NO. NO. PIECES	REF. NO.	PART NO. NO. PIECES	REF. NO.	PART NO. NO. PIECES	REF. NO.	PART NO. NO. PIECES	REF. NO.
93306-001U1	22 - 45	97013-06035	2 - 5	97880-06025	14 - 30						
93315-32224	22 - 3	97075-06025	20 - 20	97885-06008	16 - 4						
93317-22204	22 - 49		21 - 16		17 - 42						
93332-00001	22 - 6	97075-06050	20 - 15	97885-06016	17 - 33						
93332-00092	22 - 40	97075-08030	17 - 14	98507-04010	4 - 24						
93410-18M02	16 - 35		17 - 22	98580-03015	27 - 38						
93410-28M06	17 - 9	97075-10040	23 - 8	98580-04006	27 - 36						
93420-36M01	20 - 33	97080-08016	16 - 37	98580-04010	27 - 35						
93430-06024	27 - 10	97095-05012	2 - 28	98580-05010	27 - 37						
93450-09M01	4 - 4		4 - 9	98980-04006	7 - 27						
93450-17129	3 - 9		20 - 6	99001-03600	18 - 26						
93501-04M02	15 - 13	97095-06010	4 - 13	99001-08600	22 - 54						
93501-08001	18 - 39		16 - 24	99530-08012	4 - 18						
	18 - 45	97095-06012	11 - 20		10 - 12						
93503-16003	18 - 15		12 - 9								
93505-32038	18 - 27		14 - 17								
	18 - 36	97095-06014	12 - 16								
93604-08062	22 - 28	97095-06016	6 - 43								
93604-26256	18 - 40	97095-06020	2 - 30								
93605-14143	8 - 3		4 - 11								
93606-12019	2 - 3		4 - 29								
	21 - 12		12 - 2								
	23 - 7		12 - 19								
93608-12M05	21 - 8		15 - 3								
93608-16M16	6 - 40		15 - 11								
93700-06M03	16 - 10	97095-06025	6 - 38								
94701-00406	4 - 36		9 - 2								
95023-06025	10 - 4		12 - 6								
95380-03600	9 - 28		15 - 5								
95380-04600	28 - 5	97095-06030	6 - 36								
95380-05600	9 - 30		9 - 35								
	22 - 13		11 - 5								
	27 - 7	97095-08014	4 - 32								
95380-05700	15 - 23		9 - 12								
95380-06600	14 - 29	97095-08016	13 - 19								
	27 - 40	97095-08020	17 - 19								
95380-08600	9 - 14	97095-08025	23 - 13								
	11 - 13	97095-08035	11 - 10								
95380-12600	16 - 44		23 - 16								
95380-12700	17 - 26	97380-05025	27 - 8								
95680-06100	1 - 8	97380-08030	27 - 33								
95895-06025	12 - 30	97595-06520	4 - 27								
95895-06035	15 - 30	97595-06590	6 - 5								
95895-08020	8 - 10	97607-04212	19 - 12								
95895-10040	8 - 5	97880-05012	10 - 6								
97013-06016	21 - 6	97880-05016	20 - 29								
97013-06020	20 - 8	97880-05020	19 - 11								
97013-06025	21 - 3	97880-06025	10 - 10								

F40C/F60A  
PARTS CATALOGUE  
©2002 by Yamaha Motor Co., Ltd.  
1st Edition, Jul. 2002  
All rights reserved.  
Any reprinting or unauthorized use  
without the written permission of  
Yamaha Motor Co., Ltd.  
is expressly prohibited.

F40C/F60A  
CATALOGUE DE PIÈCES DÉTACHÉES  
©2002 Yamaha Motor Co., Ltd.  
1ère Edition, Juil. 2002  
Tous droits réservés.  
Toute réimpression ou utilisation  
sans la permission écrite de la  
Yamaha Motor Co., Ltd.  
est formellement interdite.